



Doosan Infracore
Portable Power

IR Ingersoll Rand

7/51, 7/71, 12/56

OPERATION AND MAINTENANCE MANUAL

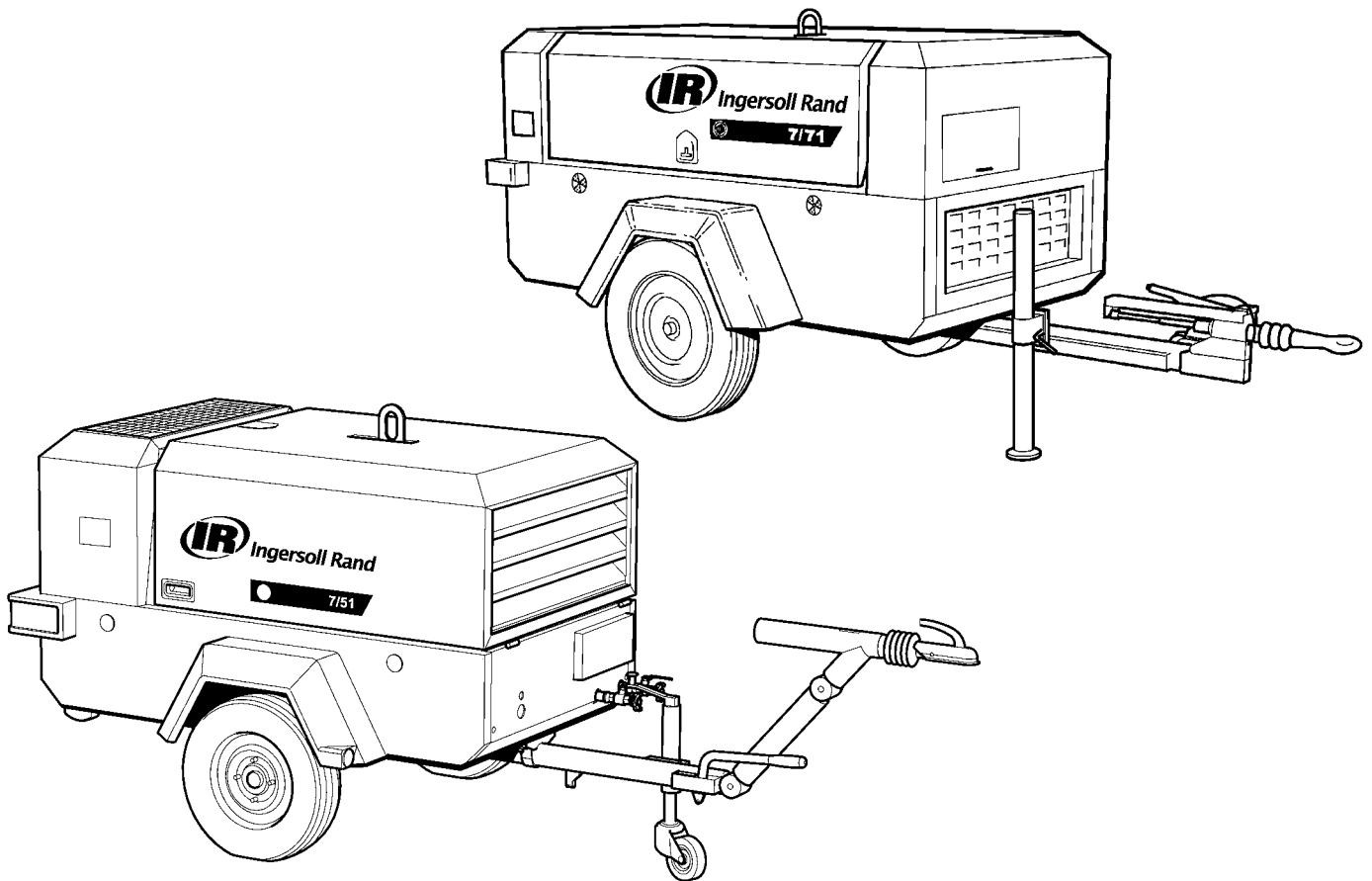

This manual contains important safety information and must be made available to personnel who operate and maintain this machine.

7/51	SERIAL No :	443500	->
------	-------------	--------	----

7/71, 12/56	SERIAL No :	522700	->
-------------	-------------	--------	----

Doosan purchased Bobcat Company from Ingersoll-Rand Company in 2007. Any reference to Ingersoll-Rand Company or use of trademarks, service marks, logos, or other proprietary identifying marks belonging to Ingersoll-Rand Company in this manual is historical or nominative in nature, and is not meant to suggest a current affiliation between Ingersoll-Rand Company and Doosan Company or the products of either.

C.C.N. : 23344104 GB
REV : A
DATE : SEPTEMBER 2008
Revised (10-12)

Machine models represented in this manual may be used in various locations world-wide. Machines sold and shipped into European Union Territories require that the machine display the EC Mark and conform to various directives. In such cases, the design specification of this machine has been certified as complying with EC directives. Any modification to any part is absolutely prohibited and would result in the CE Certification and marking being rendered invalid. A declaration of that conformity follows:



DECLARATION OF CONFORMITY WITH EC DIRECTIVES

98/37/EC, 93/68/EEC, 89/336/EEC, 2000/14/EC

We

Doosan International USA, Inc
1293 Glenway Drive
Statesville, North Carolina 28625-9218

Represented in EC by:

Doosan Trading Limited
170-175 Lake View Road
Airside Business Park
Swords
County Dublin
Ireland

Declare that, under our sole responsibility for manufacture and supply, the product(s)

7/51, 7/71, 12/56

to which this declaration relates, is (are) in conformity with the provisions of the above directives using the following principal standards

EN29001, EN60204-1, EN1012-1, PN8NTC2

Issued at Statesville on
 01-09-2008

Ric Lunsford
Manager of quality control

CONFORMITY WITH NOISE DIRECTIVE 2000/14/EC

Doosan International USA Inc declare that the following Portable Compressors have been manufactured in conformity with the directive as shown

Directive	Machine		Serial number range	Mean measured value	Guaranteed Level	Notified body
	Type	kW				
2000/14/EC Annex VI Part I	7/51	50.2	443500- 449999	97 LWA	98 LWA	A V Technology Stockport UK Nr 1067
	7/71	59.2	522700- 539999	98 LWA	99 LWA	
	12/56					

Issued at **Dobris**
SEPTEMBER 2008

Tomas Hibs
Engineering manager

EC Pressure Equipment Directive and Related Regulations

We declare that this product has been assessed according to the Pressure Equipment Directive (97/23/EC) and, in accordance with the terms of this Directive, has been excluded from the scope of this Directive. It may carry "CE" marking in compliance with other applicable EC Directives.

CALIFORNIA

Proposition 65 Warning

Diesel engine exhaust and some of its constituents are known to the State of California to cause cancer, birth defects, and other reproductive harm.

1 CONTENTS & ABBREVIATIONS

1	CONTENTS		ABBREVIATIONS & SYMBOLS
2	FOREWORD	####	Contact Ingersoll–Rand for serial number
3	WARRANTY	->#### ####->	Up to Serial No. From Serial No.
9	DECALS	*	Not illustrated
15	NOISE EMISSION	†	Option
19	MAINTENANCE RECORD FOR NOISE EMISSION CONTROL AND EXTENDED WARRANTY	AR	As required
20	SAFETY	BR	Brazil
23	GENERAL INFORMATION Dimensions Data	CN	China
27	OPERATING INSTRUCTIONS Commissioning Prior to starting Starting Stopping Emergency stopping Re-starting Monitoring during operation Decommissioning	DE	Germany
33	MAINTENANCE Routine maintenance Lubrication Speed & pressure regulation Torque settings table Compressor lubrication	DK	Denmark
45	MACHINE SYSTEMS Electrical system Piping & instrumentation system	ES	Spain
54	FAULT FINDING	FI	Finland
57	OPTIONS Lubricator. Safety. General Information. Operating Instructions. Maintenance. Fault Finding. Generator. Safety. General Information. Operating Instructions. Maintenance. Fault Finding.	FR	France
65	ENGINE INSTRUCTION MANUAL	GB	Great Britain (English)
		HA	High ambient machine
		IT	Italy
		NL	Holland
		NO	Norway
		PT	Portugal
		SE	Sweden
		US	United States
		F.H.R.G.	Fixed height running gear
		V.H.R.G.	Variable height running gear
		SECU	Small electronic control unit

The contents of this manual are considered to be proprietary and confidential to Ingersoll–Rand and should not be reproduced without the prior written permission of Ingersoll–Rand.

Nothing contained in this document is intended to extend any promise, warranty or representation, expressed or implied, regarding the Ingersoll–Rand products described herein. Any such warranties or other terms and conditions of sale of products shall be in accordance with the standard terms and conditions of sale for such products, which are available upon request.

This manual contains instructions and technical data to cover all routine operation and scheduled maintenance tasks by operation and maintenance staff. Major overhauls are outside the scope of this manual and should be referred to an authorised Ingersoll–Rand service department.

The design specification of this machine has been certified as complying with EC directives. As a result:

(a) Any machine modifications are strictly prohibited, and will invalidate EC certification.

(b) A unique specification for USA/Canada is adopted and tailored to the territory.

All components, accessories, pipes and connectors added to the compressed air system should be:

- . of good quality, procured from a reputable manufacturer and, wherever possible, be of a type approved by Ingersoll–Rand.
- . clearly rated for a pressure at least equal to the machine maximum allowable working pressure.
- . compatible with the compressor lubricant/coolant.
- . accompanied with instructions for safe installation, operation and maintenance.

Details of approved equipment are available from Ingersoll–Rand Service departments.

The use of repair parts / lubricants / fluids other than those included within the Ingersoll–Rand approved parts list may create hazardous conditions over which Ingersoll–Rand has no control. Therefore Ingersoll–Rand cannot be held responsible for equipment in which non–approved repair parts are installed.

Ingersoll–Rand reserves the right to make changes and improvements to products without notice and without incurring any obligation to make such changes or add such improvements to products sold previously.

The intended uses of this machine are outlined below and examples of unapproved usage are also given, however Ingersoll–Rand cannot anticipate every application or work situation that may arise.

IF IN DOUBT CONSULT SUPERVISION.

This machine has been designed and supplied for use only in the following specified conditions and applications:

- . Compression of normal ambient air containing no known or detectable additional gases, vapours, or particles
- . Operation within the ambient temperature range specified in the *GENERAL INFORMATION* section of this manual.

- . Generation of electricity at 110v (1ph) with centre tap earth, 230v (1ph), 230v (3ph) and 400v (3ph) / 230v (1ph) nominal at 50 Hertz. (WDG)

The use of the machine in any of the situation types listed in table 1:–

- a) Is not approved by Ingersoll–Rand,**
- b) May impair the safety of users and other persons, and**
- c) May prejudice any claims made against Ingersoll–Rand.**

TABLE 1

Use of the machine to produce compressed air for: a) direct human consumption b) indirect human consumption, without suitable filtration and purity checks.
Use of the machine outside the ambient temperature range specified in the <i>GENERAL INFORMATION SECTION</i> of this manual.
This machine is not intended and must not be used in potentially explosive atmospheres, including situations where flammable gases or vapours may be present.
Use of the machine fitted with non Ingersoll–Rand approved components / lubricants / fluids.
Use of the machine with safety or control components missing or disabled.
Use of the machine for storage or transportation of materials inside or on the enclosure except when contained within the toolbox.
GENERATOR
Use of the generator to supply load(s) greater than those specified.
Use of unsafe or unserviceable electrical equipment connected to the generator.
Use of electrical equipment: (a) Having incorrect voltage and/or frequency ratings. (b) Containing computer equipment and/or similar electronics.

The company accepts no responsibility for errors in translation of this manual from the original English version.

© **COPYRIGHT 2008**
DOOSAN COMPANY

3 WARRANTY

Ingersoll-Rand, through its distributor, warrants that each item of equipment manufactured by it and delivered hereunder to the initial user will be free of defects in material and workmanship for a period of three (3) months from initial operation or six (6) months from the date of shipment to the initial user, whichever occurs first.

With respect to the following types of equipment, the warranty period enumerated below will apply in lieu of the foregoing warranty period.

A. **Aftercoolers** – The earlier of nine (9) months from date of shipment to or six (6) months from start up by initial user.

B. **Portable Compressors, Portable Generator Sets – 9 Kva through to 550 Kva, Portable Light Towers and Air Dryers** – The earlier of twelve (12) months from shipment to or the accumulation of 2,000 hours of service by the initial user.

2.5 Kva Through to 8 Kva – The earlier of twelve (12) months from shipment to or the accumulation of 2,000 hours of operation by the initial user.

Ingersoll-Rand will provide a new part or repaired part, at its sole discretion, in place of any part which is found to be defective in material or workmanship during the period described above. Labor cost to replace the part is the responsibility of the initial user.

C. **Portable Compressor Air Ends** – The earlier of twenty-four (24) months from shipment to or the accumulation of 4,000 hours of service by the initial user. For Air Ends, the warranty against defects will include replacement of the complete Air End, provided the original Air End is returned assembled and all original seals are intact.

C1. **Portable Compressor Airend Limited Extended Warranty** – The earlier of sixty (60) months from shipment to or the accumulation of 10,000 hours of operation by the initial user. This extended warranty is limited to defects in design or defective material or workmanship in rotors, housings, bearings and gears and provided all the following conditions are met:

The original air end is returned assembled and all original seals are intact.

Continued use of genuine Ingersoll-Rand parts, fluids, oils and filters.

Maintenance is performed at prescribed intervals by authorized and properly trained service engineers.

D. **Generator Alternator – 9 Kva through to 550 Kva.** The earlier of twenty-four (24) months from shipment to or the accumulation of 4,000 hours of operation by the initial user.

2.5 Kva Through to 8 Kva – The earlier of twelve (12) months from shipment to or the accumulation of 2,000 hours of operation by the initial user.

E. **Portable Light Tower Alternator** – The earlier of twelve (12) months from shipment to or the accumulation of 2,000 hours of operation by the initial user. Light Source model only, the earlier of twenty-four (24) months from shipment to or the accumulation of 4,000 hours of operation by the initial user.

F. **Ingersoll-Rand Engines** – The earlier of twenty-four (24) months from shipment to or the accumulation of 4,000 hours of operation by the initial user.

G. **Ingersoll-Rand Platinum Drive Train Limited Extended Warranty** – Platinum drive train refers to the Ingersoll-Rand Engine and Airend combination. The earlier of sixty (60) months from shipment to, or the accumulation of 10,000 hours of operation by the initial user. The starter, alternator, fuel injection system and all electrical components are excluded from this extended warranty. The airend seal and drive coupling are included in the warranty but airend drive belts are excluded. This limited extended warranty is automatically available when meeting the following conditions are met:

1. The original airend is returned assembled and unopened.

2. Continued use of genuine Ingersoll-Rand parts, fluids, oil and filters.

3. Maintenance is performed at prescribed intervals by authorized and properly trained service engineers.

Ingersoll-Rand shall be provided with such information as it requires to confirm that these conditions have been complied with.

H1. **Construction Tools, (Portable Power range only)** – Twelve (12) months from shipment to initial user. Ingersoll-Rand will provide a new part or repaired part, at its sole discretion, in place of any part which is found to be defective in material or workmanship during the period described above. Labor cost to replace the part is the responsibility of the initial user.

H2. **Construction Tools Limited Extended Warranty, (Portable Power range only)** – Thirty-six (36) months from shipment to initial user. This extended warranty is automatically available only when the tool is registered with Ingersoll-Rand by completing and submitting the Warranty Registration form. Ingersoll-Rand will provide a new part or repaired part, at its sole discretion, in place of any part which is found to be defective in material or workmanship during the period described above. Labor cost to replace the part is the responsibility of the initial user.

I. **Spare Parts** – Six (6) months from date of shipment to the initial user.

Ingersoll-Rand will provide a new part or repaired part, at its sole discretion, in place of any part that is found to be defective in material and workmanship during the period described above. Such parts will be repaired or replaced without charge to the initial user during normal working hours at the place of business of an Ingersoll-Rand distributor authorized to sell the type of equipment involved or other establishment authorized by Ingersoll-Rand. User must present proof of purchase at the time of exercising warranty.

The above warranties do not apply to failures occurring as a result of abuse; misuse, negligent repairs, corrosion, erosion and normal wear and tear, alterations or modifications made to the product without express written consent of Ingersoll-Rand; or failure to follow the recommended operating practices and maintenance procedures as provided in the product's operating and maintenance publications.

Accessories or equipment furnished by Ingersoll-Rand, but manufactured by others, including, but not limited to, engines, tires, batteries, engine electrical equipment, hydraulic transmissions, carriers, shall carry only the manufacturers warranty, which Ingersoll-Rand can lawfully assign to the initial user.

THE ABOVE WARRANTIES ARE IN LIEU OF ALL OTHER WARRANTIES EXPRESSED OR IMPLIED, (EXCEPT THAT OF TITLE), AND THERE ARE NO WARRANTIES OF MERCHANTABILITY OR OF FITNESS FOR A PARTICULAR PURPOSE.

GENERAL WARRANTY INFORMATION – ESA

			COMMENTS
PORTABLE COMPRESSOR	PACKAGE	12 MONTHS / 2,000 HOURS	COVERS CONTROLS, SWITCHES, SHEET METAL, RADIATOR, OIL COOLER, RECEIVER, PIPEWORK, ELECTRICAL CIRCUIT ETC.
	AIREND	24 MONTHS / 4,000 HOURS	60 MONTHS / 10,000 HOURS. EXTENDED LIMITED WARRANTY AVAILABLE ON MAJOR COMPONENTS. REFER TO OPERATOR'S MANUAL.
	ENGINE	SEE BELOW	

2.5kVA – 8kVA GENERATORS	PACKAGE	12 MONTHS / 2,000 HOURS	CONTACT IR NETWORK FOR WARRANTY (PARTS ONLY NO LABOUR).
	ALTERNATOR	12 MONTHS / 2,000 HOURS	CONTACT IR NETWORK FOR WARRANTY (PARTS ONLY NO LABOUR).
	ENGINE	SEE BELOW	

9kVA – 550kVA GENERATORS	PACKAGE	12 MONTHS / 2,000 HOURS	COVERS CONTROLS, SWITCHES, SHEET METAL, ELECTRICAL CIRCUIT ETC.
	ALTERNATOR	24 MONTHS / 4,000 HOURS	CONTACT IR NETWORK FOR WARRANTY.
	ENGINE	SEE BELOW	

LIGHT TOWER	PACKAGE	12 MONTHS / 2,000 HOURS	COVERS CONTROLS, SWITCHES, SHEET METAL, ELECTRICAL CIRCUIT ETC.
	ALTERNATOR	12 MONTHS / 2,000 HOURS	EXTENDED WARRANTY OF 24 MONTHS / 4,000 HRS. FOR LIGHTSOURCE INTRODUCED 8/16/99.
	ENGINE	SEE BELOW	

ENGINES			
	MONTHS	HOURS	COMMENTS
CATERPILLAR	12	UNLIMITED	EXTENDED WARRANTY PROVIDED VIA ENGINE SUPPLIER'S OWN APPROVED NETWORK AT TIME OF PURCHASE.
CUMMINS	24	2,000	EXTENDED WARRANTY PROVIDED VIA ENGINE SUPPLIER'S OWN APPROVED NETWORK AT TIME OF PURCHASE.
PERKINS	12	UNLIMITED	IF UNDER 500 HOURS IN FIRST YEAR THEN BELOW APPLIES.
	24	1,000	ALL COMPONENTS COVERED EXCLUDING INJECTORS.
JOHN DEERE (IN COMPRESSORS) (IN GENERATORS)	24	2,000	5 YRS/5,000 HRS USING OEM FLUIDS AND FILTERS WITH \$250 DEDUCTABLE
	24	2,000	24 MONTHS / 4,000 HRS. AVAILABLE FROM IR WITH USE OF GENUINE IR PARTS AND OILS AT PRESCRIBED SERVICE INTERVALS. CONTACT IR NETWORK.
DEUTZ	0 – 12	UNLIMITED	ALL COMPONENTS COVERED.
	13 – 24	UNLIMITED	MAJOR COMPONENTS COVERED. FURTHER EXTENDED WARRANTY ON MAJOR COMPONENTS PROVIDED VIA ENGINE SUPPLIER'S OWN APPROVED NETWORK AT TIME OF PURCHASE.
INGERSOLL-RAND	24	4,000	EXTENDED WARRANTY OF 60 MONTHS / 10,000 HRS. WHEN USING GENUINE INGERSOLL-RAND FLUIDS AND PARTS ON MAJOR COMPONENTS.

5 WARRANTY

KUBOTA (North America only)	24	2,000	EXTENDED WARRANTY OF 36 MONTHS / 3,000 HRS. ON MAJOR COMPONENTS, PARTS ONLY, AVAILABLE FROM KUBOTA.
(Western Europe and Oceania)	24	2,000	NO EXTENDED WARRANTY AVAILABLE.
(Central and South America, Asia, Middle East and Africa)	12	1,000	NO EXTENDED WARRANTY AVAILABLE.
MITSUBISHI	24	2,000	2YRS / 4,000 HRS USING IR FLUIDS AND FILTERS
VOLVO	24	2,000	2YRS / 4,000 HRS USING IR FLUIDS AND FILTERS

PARTS			
	MONTHS	HOURS	COMMENTS
INGERSOLL-RAND	6	UNLIMITED	PARTS ONLY AVAILABLE FROM IR NETWORK.

AIREND EXCHANGE			
	MONTHS	HOURS	COMMENTS
AIREND	12	2,000	24 MONTHS / 4,000 HRS. AVAILABLE FROM IR NETWORK.

CONSTRUCTION TOOLS			
	MONTHS	HOURS	COMMENTS
CONSTRUCTION TOOLS	12	N/A	OPTIONAL 36 MONTHS EXTENDED WARRANTY AVAILABLE FROM IR. ALL WARRANTY COVERS PARTS ONLY REPLACEMENT.

**NOTE: Actual warranty times may change.
Consult the Manufacturer's warranty policy as shipped with each new product.**

Extended Limited Airend Warranty

Ingersoll–Rand Portable Compressor Division is pleased to announce the availability of extended limited airend warranty. Announcement of the extended warranty coincides with the introduction of Pro–Tec™ Compressor Fluid. Pro–Tec™ Compressor Fluid is an amber coloured fluid specially formulated for Portable Compressors and is being provided as the factory filled fluid for all machines except ¹ XHP650/900/1070

All machines have the standard airend warranty, – *The earlier of 24 months from shipment to, or the accumulation of 4000 hours of service by the initial user.*

The warranty against defects will include replacement of the complete Airend, provided the original Airend is returned assembled and unopened.

The optional limited warranty is the earlier of 60 months from shipment to, or the accumulation of 10,000 hours of service. The optional warranty is limited to defects in major components (rotors, housings, gears and bearings), and is automatically available when the following conditions are met:

1. The original airend is returned assembled and unopened.
2. Submissions of proof that Ingersoll–Rand fluid, filters and separators have been used. Refer to the Operation and Parts manual for the correct fluids, filters and separator elements required.
3. Submissions of proof that maintenance intervals have been followed.

WARRANTY	TIME	*BARE AIREND	**AIREND COMPONENTS
STANDARD	2YRS / 4,000HRS	100% PARTS & LABOUR	100% PARTS & LABOUR
OPTIONAL	5YRS / 10,000HRS	100% PARTS & LABOUR	0%

*BARE AIREND – pertains to major airend parts (rotors, housings, gears and bearings).

**AIREND COMPONENTS – pertains to auxiliary attachments to the bare airend (seals, pumps, valves, tubes, hoses, fittings and filter housing).

Pro–Tec™ and XHP505 Compressor Fluids are available from your local Ingersoll–Rand branch or distributor.

For units operating within the USA & Canada, call the Mocksville Product Support Department on 1–800–633–5206

¹ XHP650/900/1070/1170 will continue to use XHP505 and will have the extended warranty when above conditions are met.

WARRANTY REGISTRATION

FOR UNITS SOURCED FROM DUBLIN, IRELAND

Complete Machine Registration

To initiate the machine warranty, fill out the "Warranty Registration" form 85040285 supplied as part of the machine documentation, keep a copy for your records and mail the original to:

**Doosan Warranty Team
Doosan Trading Limited
170/175 Lakeview Drive
Airside Business Park
Swords, Co. Dublin
Ireland**

Fax: (+353) 1 870 7404

Email: doosanwarranty@dii.doosan.com

Note: Completion of this form validates the warranty.

Engine Registration:

I-R powered machines do not require separate engine registration.

Deutz require a separate engine registration form to be completed and mailed direct to their Cologne office. The form is supplied as part of the machine documentation for Deutz powered machines.

Caterpillar, Cummins and Perkins do not require a separate registration form but they stipulate that any new engine should be registered with their local dealer to initiate warranty.

You **MUST** provide proof of the "in-service" date when requesting engine warranty repairs.

**PORTABLE POWER
EXTENDED WARRANTY REGISTRATION FORM**

Customer Details

Company Name : _____

Contact Name : _____

Signature : _____

Company Address : _____

Post / Zip Code : _____

Country : _____

Phone Number : _____

Fax Number : _____

e-mail : _____

Service Provider Details

Service Provider / Distributor : _____

Branch Office : _____

Machine Details

Product Type : _____

Model : _____

Serial Number : _____

Engine Serial Number : _____

Engine Model Number : _____









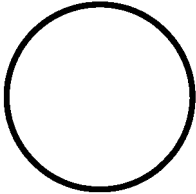
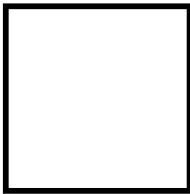
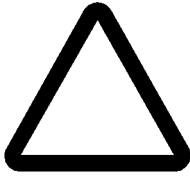

Airend Serial Number : _____

Alternator Serial Number : _____

Date of start up : _____

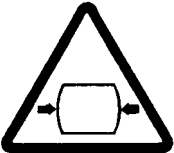
SAMPLE

GRAPHIC FORM AND MEANING OF ISO SYMBOLS

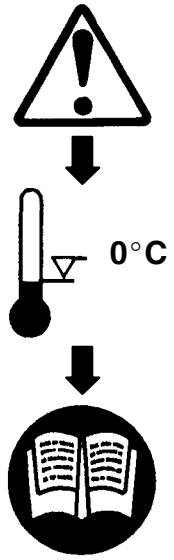
		
Prohibition / Mandatory	Information / Instructions	Warning
 <p>WARNING: Electrical shock risk.</p>	 <p>WARNING – Pressurised component or system.</p>	 <p>WARNING – Hot surface.</p>
 <p>WARNING – Pressure control.</p>	 <p>WARNING – Corrosion risk.</p>	 <p>WARNING – Air/gas flow or Air discharge.</p>
 <p>WARNING – Pressurised vessel.</p>	 <p>WARNING – Hot and harmful exhaust gas.</p>	 <p>WARNING – Maintain correct tyre pressure. (Refer to the GENERAL INFORMATION section of this manual).</p>
 <p>WARNING – Flammable liquid.</p>	 <p>WARNING – Before connecting the tow bar or commencing to tow consult the operation and maintenance manual.</p>	 <p>WARNING – For operating temperature below 0°C, consult the operation and maintenance manual.</p>

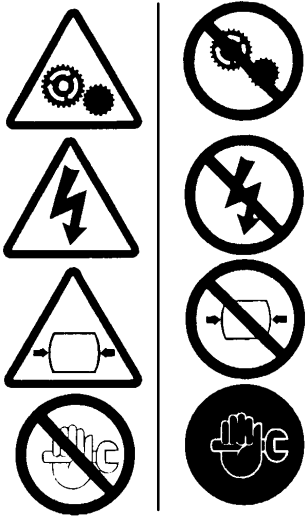

WARNING – Do not undertake any maintenance on this machine until the electrical supply is disconnected and the air pressure is totally relieved.



WARNING – Consult the operation and maintenance manual before commencing any maintenance.



Do not breathe the compressed air from this machine.



Do not remove the Operating and Maintenance manual and manual holder from this machine.



Do not stack.



Do not operate the machine without the guard being fitted.



Do not stand on any service valve or other parts of the pressure system.



Do not operate with the doors or enclosure open.



Do not use fork lift truck from this side.



Do not exceed the trailer speed limit.



No naked lights.



Do not open the service valve before the airhose is attached.



Use fork lift truck from this side only.

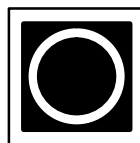

Emergency stop.



Tie down point



Lifting point.



On (power).

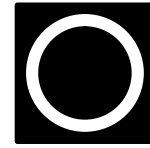

Off (power).



Read the Operation and Maintenance manual before operation or maintenance of this machine is undertaken.

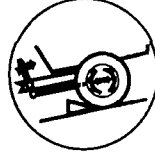

When parking use prop stand, handbrake and wheel chocks.

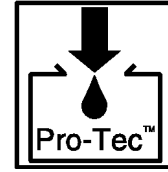

Compressor oil filling

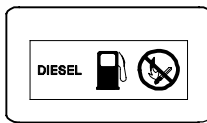

Diesel fuel
No open flame.

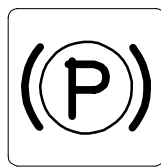

Parking brake.

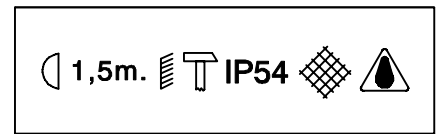

Rough Service Designation.
Wet Location Operation.

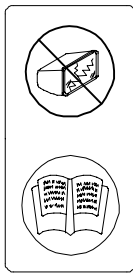

Replace any cracked protective shield.

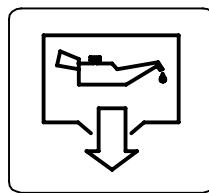

Oil drain.

Look for these signs on machines shipped to markets in North America, which point out potential hazards to the safety of you and others. Read and understand thoroughly. Heed warnings and follow instructions. If you do not understand, inform your supervisor.

⚠ DANGER

Red background
Indicates the presence of a hazard which **WILL** cause serious injury, death or property damage, if ignored.

⚠ WARNING

Orange background
Indicates the presence of a hazard which **CAN** cause serious injury, death or property damage, if ignored.

⚠ CAUTION

Yellow background
Indicates the presence of a hazard which **WILL** or can cause injury or property damage, if ignored.

NOTICE

Blue background
Indicates important set-up, operating or maintenance information.



⚠ DANGER



Air discharged from this machine can contain carbon monoxide or other contaminants which will cause serious injury or death. Do not breathe this air.



⚠ WARNING

Trapped air pressure. Can cause serious injury or death.

Close service valve and operate tool to vent trapped air before performing any service.

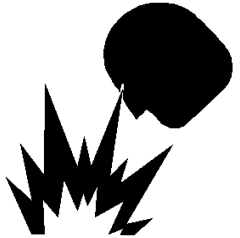

⚠ WARNING

Hot pressurized fluid. Can cause serious burns.

Do not open radiator while hot.





⚠ WARNING

Rotating Fan Blade. CAN cause serious injury.

Do NOT operate with guard removed.





⚠ WARNING

Improper operation of this equipment. CAN cause serious injury or death.

Read Operator's Manual supplied with this machine before operation or servicing.

Modification or alteration of this machine. CAN cause serious injury or death.

Do NOT alter or modify this machine without the express written consent of the manufacturer.



⚠ WARNING

Trapped air pressure. Can cause serious injury or death.

Close service valve and operate tool to vent trapped air before performing any service.

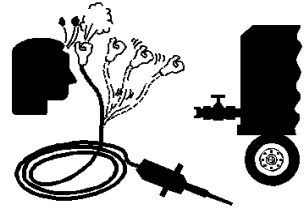

⚠ WARNING

Disconnected Air Hoses Whip. CAN cause serious injury or death.

When using air tools attach safety device (OSHA Valve) at source of air supply for each tool.

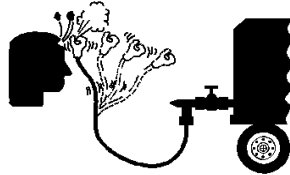

WARNING

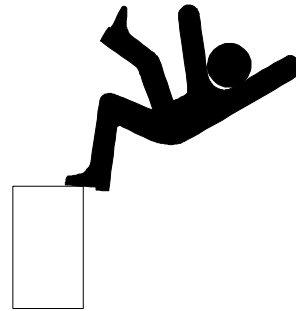

Falling off machine. CAN cause serious injury or death.

Access Lifting Bail from inside machine.



⚠ WARNING

High pressure air. Can cause serious injury or death.

Relieve pressure before removing filler plugs/caps, fittings or covers.

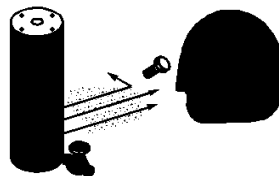

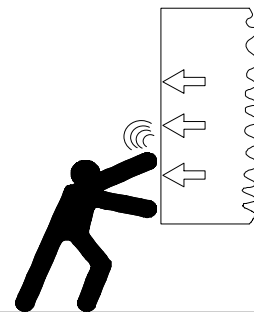

WARNING

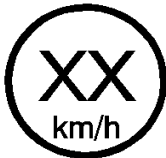

Door under pressure CAN cause serious injury.

Use both hands to open door when machine is running.





WARNING



**Collapsing propstand.
Can cause serious injury.**

Clamp propstand securely

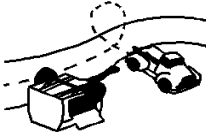

**Excessive towing speed.
Can cause serious injury or death.**

Do NOT exceed 65 mph (105 km/hr)

WARNING



Excessive Towing Speed. CAN cause serious injury or death.

Do NOT Tow on Highway.
Do NOT exceed 20 mph (32 km/h)

For Highway Towable Units.

For Non-Highway Towable Machines

FREE SAFETY DECALS!

Safety Decals are available **free** of charge. Safety decals are identified by the decal heading:
DANGER, WARNING or CAUTION.

Decal part numbers are on the bottom of each decal and are also listed in the compressor's parts manual. Submit orders for Safety Decals to the **Doosan Portable Power EMEA Aftermarket Department**. The no charge order should contain only Safety Decals. Help promote product safety! Assure that decals are present on the machines. Replace decals that are not readable.

This section pertains only to machines distributed within the United States.

WARNING

TAMPERING WITH NOISE CONTROL SYSTEM PROHIBITED

Federal law prohibits the following acts or the causing thereof:

(1) The removal or rendering inoperative by any persons, other than for purposes of maintenance, repair, or replacement, of any device or element of design incorporated into any new compressor for the purpose of noise control prior to its sale or delivery to the ultimate purchaser or while it is in use; or (2) the use of the compressor after such device or element of design has been removed or rendered inoperative by any person.

Among those acts included in the prohibition against tampering are these:

1. Removal or rendering inoperative any of the following:
 - a. the engine exhaust system or parts thereof
 - b. the air intake system or parts thereof
 - c. enclosure or parts thereof
2. Removal of any of the following:
 - a. fan shroud
 - b. vibration mounts
 - c. sound absorption material
3. Operation of the compressor with any of the enclosure doors open.

Compressor Noise Emission Control Information

A. The removal or rendering inoperative, other than for the purpose of maintenance, repair, or replacement of any noise control device or element of design incorporated into this compressor in compliance with the noise control act;

B. The use of this compressor after such device or element of design has been removed or rendered inoperative.

Note: the above information applies only to units that are built in compliance with the U.S. Environmental Protection Agency.

Ingersoll-Rand Company reserves the right to make changes or add improvements without notice and without incurring any obligation to make such changes or add such improvements to products sold previously.

The Purchaser is urged to include the above provisions in any agreement for any resale of this compressor.

NOISE EMISSION CONTROL

MAINTENANCE LOG

COMPRESSOR MODEL _____
SERIAL NO. _____
USER UNIT NO. _____

UNIT IDENTIFICATION
ENGINE MAKE & MODEL: _____
SERIAL NO.: _____
PURCHASER OR OWNER: _____
ADDRESS: _____

DEALER OR DISTRIBUTOR FROM WHOM PURCHASED:

DATE PURCHASED: _____

The Noise Control Act of 1972 (86 Stat. 1234) prohibits tampering with the noise control system of any compressor manufactured and sold under the above regulations, specifically the following acts or the causing thereof:

- (1) The removal or rendering inoperative by any persons, other than for purposes of maintenance, repair, or replacement, of any device or element of design incorporated into any new compressor for the purpose of noise control prior to its sale or delivery to the ultimate purchaser or while it is in use;
- or (2) the use of the compressor after such a device or element of design has been removed or rendered inoperative by any person.

NOISE EMISSION WARRANTY

The manufacturer warrants to the ultimate purchaser and each subsequent purchaser that this air compressor was designed, built and equipped to conform at the time of sale to the first retail purchaser, with all applicable U.S. EPA Noise Control Regulations.

This warranty is not limited to any particular part, component, or system of the air compressor. Defects in the design, assembly, or in any part, component, or system of the compressor which, at the time of sale to the first retail purchaser, caused noise emissions to exceed Federal Standards are covered by this warranty for the life of the air compressor. (40FR204.58-1).

17 NOISE EMISSION

INTRODUCTION

The unit for which this Maintenance Log is provided conforms to U.S. E.P.A. Regulations for Noise Emissions, applicable to Portable Air Compressors.

The purpose of this book is to provide (1) the Maintenance Performance Schedule below for all required noise emission controls and (2) space so that the purchaser or owner can record what maintenance was done, by whom, where and when. Detailed instructions on the maintenance items below are given on the following page.

MAINTENANCE SCHEDULE

ITEM	AREA	PERIOD
A.	COMPRESSED AIR LEAKS	AS DETECTED
B.	SAFETY AND CONTROL SYSTEMS	AS DETECTED
C.	ACOUSTIC MATERIALS	DAILY
D.	FASTENERS	100 HOURS
E.	ENCLOSURE PANELS	100 HOURS
F.	AIR INTAKE & ENGINE EXHAUST	100 HOURS
G.	COOLING SYSTEMS	250 HOURS
H.	ISOLATION MOUNTS	250 HOURS
I.	ENGINE OPERATION	SEE OPERATOR'S MANUAL
J.	FUELS & LUBRICANTS	SEE OPERATOR'S MANUAL

A. COMPRESSED AIR LEAKS

Correct all compressed air leaks during the first shutdown period after discovery. If severe enough to cause serious noise problems and efficiency loss, shut down immediately and correct the leak(s).

B. SAFETY AND CONTROL SYSTEMS

Repair or replace all safety and control systems or circuits as malfunction occurs. No compressor should be operated with **either** system bypassed, disabled, or nonfunctional.

C. ACOUSTIC MATERIALS

In daily inspections, observe these materials. Maintain all acoustic material as nearly as possible in its original condition. Repair or replace all sections that have: 1) sustained damage, 2) have partially separated from panels to which they were attached, 3) are missing, or have otherwise deteriorated due to severe operating or storage conditions.

D. FASTENERS

All fasteners such as hinges, nuts, bolts, clamps, screws, rivets and latches should be inspected for looseness after each 100 hours of operation. They should be retightened, repaired, or – if missing – replaced immediately to prevent subsequent damage and noise emission increase.

E. ENCLOSURE PANELS

Enclosure panels should also be inspected at 100 hour operational intervals. All panels that are warped, punctured, torn, or otherwise deformed, such that their noise containment function is reduced, should be repaired or replaced before the next operation interval. Doors, access panels, and hatch closures especially, should be checked and adjusted at this time to insure continuous sealing between gasket or acoustic material and the mating frame.

F. AIR INTAKE AND ENGINE EXHAUST

Engine and compressor air intake and engine exhaust systems should be inspected after each 100 hours of operation for loose, damaged, or deteriorated components. Repairs or replacements should be made before the next period of use.

G. COOLING SYSTEMS

All components of the cooling systems for engine water and compressor oil should be inspected every 250 hours of use. Any discrepancies found should be corrected before placing the unit back in operation. Unrestricted airflow over the radiator and oil cooler must be maintained at all times during operation.

H. ISOLATION MOUNTS

Engine/airendisolation mounts should be inspected after each 250 hours of operation. Those mounts with cracks or splits in the molded rubber, or with bent or broken bolts due to operation or storage in severe environments, all should be replaced with equivalent parts.

I. ENGINE OPERATION

Inspect and maintain engine condition and operation as recommended in the manuals supplied by the engine manufacturer.

J. FUELS AND LUBRICANTS

Use only the types and grades of fuels and lubricants recommended in the Ingersoll-Rand Company and Engine Manufacturer's Operator and Maintenance Manuals.

MAINTENANCE RECORD FOR NOISE EMISSION CONTROL AND EXTENDED WARRANTY					
ITEM NO.	DESCRIPTION OF WORK OR COMMENTS	HOURLMETER READING	MAINT/INSPECT DATE	LOCATION CITY/STATE	WORK DONE BY (NAME)

WARNINGS

Warnings call attention to instructions which must be followed precisely to avoid injury or death.

CAUTIONS

Cautions call attention to instructions which must be followed precisely to avoid damaging the product, process or its surroundings.

NOTES

Notes are used for supplementary information.

General Information

Never operate unit without first observing all safety warnings and carefully reading the operation and maintenance manual shipped from the factory with this machine.

Ensure that the operator reads and *understands* the decals and consults the manuals before maintenance or operation.

Ensure that the Operation and Maintenance manual, and the manual holder, are not removed permanently from the machine.

Ensure that maintenance personnel are adequately trained, competent and have read the Maintenance Manuals.

Make sure that all protective covers are in place and that the canopy/doors are closed during operation.

The specification of this machine is such that the machine is not suitable for use in flammable gas risk areas. If such an application is required then all local regulations, codes of practice and site rules must be observed. To ensure that the machine can operate in a safe and reliable manner, additional equipment such as gas detection, exhaust spark arrestors, and intake (*shut-off*) valves may be required, dependant on local regulations or the degree of risk involved.

A weekly visual check must be made on all fasteners/fixing screws securing mechanical parts. In particular, safety-related parts such as coupling hitch, drawbar components, road-wheels, and lifting bail should be checked for total security.

All components which are loose, damaged or unserviceable, must be rectified without delay.

Air discharged from this machine may contain carbon monoxide or other contaminants which will cause serious injury or death. Do not breathe this air.

This machine produces loud noise with the doors open or service valve vented. Extended exposure to loud noise can cause hearing loss. Always wear hearing protection when doors are open or service valve is vented.

Never inspect or service unit without first disconnecting battery cable(s) to prevent accidental starting.

Do not use petroleum products (solvents or fuels) under high pressure as this can penetrate the skin and result in serious illness. wear eye protection while cleaning unit with compressed air to prevent debris from injuring eye(s).

Rotating fan blade can cause serious injury. Do not operate without guard in place.

Use care to avoid contacting hot surfaces (engine exhaust manifold and piping, air receiver and air discharge piping, etc.).

Ether is an extremely volatile, highly inflammable gas. When it is specified as a starting aid, use sparingly. **DO NOT USE ETHER IF THE MACHINE HAS GLOW PLUG STARTING AID OR ENGINE DAMAGE WILL RESULT.**

Never operate unit with guards, covers or screens removed. Keep hands, hair, clothing, tools, blow gun tips, etc. well away from moving parts.

Compressed air

Compressed air can be dangerous if incorrectly handled. Before doing any work on the unit, ensure that all pressure is vented from the system and that the machine cannot be started accidentally.

Ensure that the machine is operating at the rated pressure and that the rated pressure is known to all relevant personnel.

All air pressure equipment installed in or connected to the machine must have safe working pressure ratings of at least the machine rated pressure.

If more than one compressor is connected to one common downstream plant, effective check valves and isolation valves must be fitted and controlled by work procedures, so that one machine cannot accidentally be pressurised / over pressurised by another.

Compressed air must not be used for a direct feed to any form of breathing apparatus or mask.

High Pressure Air can cause serious injury or death. Relieve pressure before removing filler plugs/caps, fittings or covers.

Air pressure can remain trapped in air supply line which can result in serious injury or death. Always carefully vent air supply line at tool or vent valve before performing any service.

The discharged air contains a very small percentage of compressor lubricating oil and care should be taken to ensure that downstream equipment is compatible.

If the discharged air is to be ultimately released into a confined space, adequate ventilation must be provided.

When using compressed air always use appropriate personal protective equipment.

All pressure containing parts, especially flexible hoses and their couplings, must be regularly inspected, be free from defects and be replaced according to the Manual instructions.

Avoid bodily contact with compressed air.

The safety valve located in the separator tank must be checked periodically for correct operation.

Whenever the machine is stopped, air will flow back into the compressor system from devices or systems downstream of the machine unless the service valve is closed. Install a check valve at the machine service valve to prevent reverse flow in the event of an unexpected shutdown when the service valve is open.

Disconnected air hoses whip and can cause serious injury or death. Always attach a safety flow restrictor to each hose at the source of supply or branch line in accordance with OSHA Regulation 29CFR Section 1926.302(b).

Never allow the unit to sit stopped with pressure in the receiver-separator system.

Materials

The following substances *may* be produced during the operation of this machine:

- . brake lining dust
- . engine exhaust fumes

AVOID INHALATION

Ensure that adequate ventilation of the cooling system and exhaust gases is maintained at all times.

The following substances are used in the manufacture of this machine and *may* be hazardous to health if used incorrectly:

- . compressor lubricant
- . engine lubricant
- . preservative grease
- . rust preventative
- . diesel fuel
- . battery electrolyte

AVOID INGESTION, SKIN CONTACT AND INHALATION OF FUMES.

Should compressor lubricant come into contact with the eyes, then irrigate with water for at least 5 minutes.

Should compressor lubricant come into contact with the skin, then wash off immediately.

Consult a physician if large amounts of compressor lubricant are ingested.

Consult a physician if compressor lubricant is inhaled.

Never give fluids or induce vomiting if the patient is unconscious or having convulsions.

Safety data sheets for compressor and engine lubricants should be obtained from the lubricant supplier.

Never operate the engine of this machine inside a building without adequate ventilation. Avoid breathing exhaust fumes when working on or near the machine.

This machine may include such materials as oil, diesel fuel, antifreeze, brake fluid, oil/air filters and batteries which may require proper disposal when performing maintenance and service tasks. Contact local authorities for proper disposal of these materials.

Battery

A battery contains sulphuric acid and can give off gases which are corrosive and potentially explosive. Avoid contact with skin, eyes and clothing. In case of contact, flush area immediately with water.

DO NOT ATTEMPT TO SLAVE START A FROZEN BATTERY SINCE THIS MAY CAUSE IT TO EXPLODE.

Exercise extreme caution when using booster battery. To jump battery, connect ends of one booster cable to the positive (+) terminal of each battery. Connect one end of other cable to the negative (-) terminal of the booster battery and other end to a ground connection away from dead battery (to avoid a spark occurring near any explosive gases that may be present). After starting unit, always disconnect cables in reverse order.

Radiator

Hot engine coolant and steam can cause injury. Ensure that the radiator filler cap is removed with due care and attention.

Do not remove the pressure cap from a HOT radiator. Allow radiator to cool down before removing pressure cap.

Generator sets

The generator set is designed for safety in use. However, the responsibility for safe operation rests with those who install, use and maintain it. The following safety precautions are offered as a guide, which, if conscientiously followed, will minimise the possibility of accidents throughout the useful life of this equipment.

Emergency Stop Controls

Important Note:- In addition to the key operated emergency stop control on the main control panel, a second control is provided at the socket control panel in the event of electrical hazards associated with generator operation. Use this second control to immediately isolate all electrical power to all sockets, then use the key control to stop the engine.

Operation of the generator must be in accordance with recognised electrical codes and local health and safety codes.

The generator set should be operated by those who have been trained in its use and delegated to do so, and who have read and understand the operator's manual. *Failure to follow the instructions, procedures and safety precautions in the manual may increase the possibility of accidents and injuries.*

Do not start the generator set unless it is safe to do so. Do not attempt to operate the generator set with a known unsafe condition. Fit a danger notice to the generator set and render it inoperative by disconnecting the battery and disconnecting all ungrounded conductors so others who may not know of the unsafe condition will not attempt to operate it until the condition is corrected.

An earth point is provided beneath the socket outlets.

The generator set should only be used with the earth point connected directly to the general earth/ground mass. An earth spike kit is available as an optional extra for this purpose (refer to the *parts catalogue*).

WARNING: DO NOT OPERATE THE MACHINE UNLESS IT HAS BEEN SUITABLY EARTHED.

Generator sets must be connected to the load only by trained and qualified electricians who have been delegated to do so, and when required by applicable regulations, their work should be inspected, and accepted by the inspection agency having authority, prior to attempting to operate the generator set.

Do not make contact with electrically energised parts of the generator set and/or interconnecting cables or conductors with any part of the body or with any non-insulated conductive object.

Make sure the generator set is effectively grounded in accordance with all applicable Regulations prior to attempting to make or break load connections and prior to attempting operation.

Do not attempt to make or break electrical connections to generator sets standing in water or on wet ground.

Prior to attempting to make or break electrical connections at the generator set, stop the engine, disconnect the battery and disconnect and lock out the ungrounded conductors at the load end.

Keep all parts of the body and any hand-held tools or other conductive objects, away from exposed live parts of the generator set engine electrical system. Maintain dry footing, stand on insulating surfaces and do not contact any other portion of the generator set when making adjustments or repairs to exposed live parts of the generator set engine electrical system.

Replace the generator set terminal compartment cover as soon as connections have been made or broken. Do not operate the generator set without the terminal cover secured firmly in place.

Close and lock all access doors when the generator set is left unattended.

Do not use extinguishers intended for Class A or Class B fires on electrical fires. Use only extinguishers suitable for class *BC* or class *ABC* fires.

Keep the towing vehicle or equipment carrier, generator set, connecting cables, tools and all personnel at least 3 metres from all power lines and buried power cables, other than those connected to the generator set.

Attempt repairs only in clean, dry, well lighted and ventilated areas.

Connect the generator set only to loads and/or electrical systems that are compatible with its electrical characteristics and that are within its rated capacity.

Transport

When loading or transporting machines ensure that the specified lifting and tie down points are used.

When loading or transporting machines ensure that the towing vehicle, its size, weight, towing hitch and electrical supply are all suitable to provide safe and stable towing at speeds either, up to the legal maximum for the country in which it is being towed or, as specified for the machine model if lower than the legal maximum.

Ensure that the maximum trailer weight does not exceed the maximum gross weight of the machine (by limiting the equipment load), limited by the capacity of the running gear.

Note:

Gross mass (on data plate) is for the basic machine and fuel only, excluding any fitted options, tools, equipment and foreign materials.

Before towing the machine, ensure that:-

- . the tyres and towing hitch are in a serviceable condition.
- . the canopy is secure.
- . all ancillary equipment is stored in a safe and secure manner.
- . the brakes and lights are functioning correctly and meet necessary road traffic requirements.
- . break-away cables/safety chains are connected to the towing vehicle.

The machine must be towed in a level attitude in order to maintain correct handling, braking and lighting functions. This can be achieved by correct selection and adjustment of the vehicle towing hitch and, on variable height running gear, adjustment of the drawbar.

To ensure full braking efficiency, the front (towing eye) section must always be set level.

When adjusting variable height running gear:-

Ensure front (towing eye) section is set level

When raising towing eye, set rear joint first, then front joint.

When lowering towing eye, set front joint first, then rear joint.

After setting, fully tighten each joint by hand and then tighten further to the next pin. Refit the pin.

When parking always use the handbrake and, if necessary, suitable wheel chocks.

Make sure wheels, tyres and tow bar connectors are in safe operating condition and tow bar is properly connected before towing.

Safety chains / connections and their adjustment

The legal requirements for the joint operation of the breakaway cable and safety chains are as yet unidentified by 71/320/EEC or UK regulations. Consequently we offer the following advice / instructions.

Where brakes only are fitted:

- a) Ensure that the breakaway cable is securely coupled to the handbrake lever and also to a substantial point on the towing vehicle.
- b) Ensure that the effective cable length is as short as possible, whilst still allowing enough slackness for the trailer to articulate without the handbrake being applied.

Where brakes and safety chains are fitted:

- a) Loop the chains onto the towing vehicle using the towing vehicle hitch as an anchorage point, or any other point of similar strength.
- b) Ensure that the effective chain length is as short as possible whilst still allowing normal articulation of the trailer and effective operation of the breakaway cable.

Where safety chains only are fitted:

- a) Loop the chains onto the towing vehicle using the towing vehicle hitch as an anchorage point, or any other point of similar strength.
- b) When adjusting the safety chains there should be sufficient free length in the chains to allow normal articulation, whilst also being short enough to prevent the towbar from touching the ground in the event of an accidental separation of the towing vehicle from the trailer.

7/51 FIXED HEIGHT RUNNING GEAR
 Braked version (Knott)

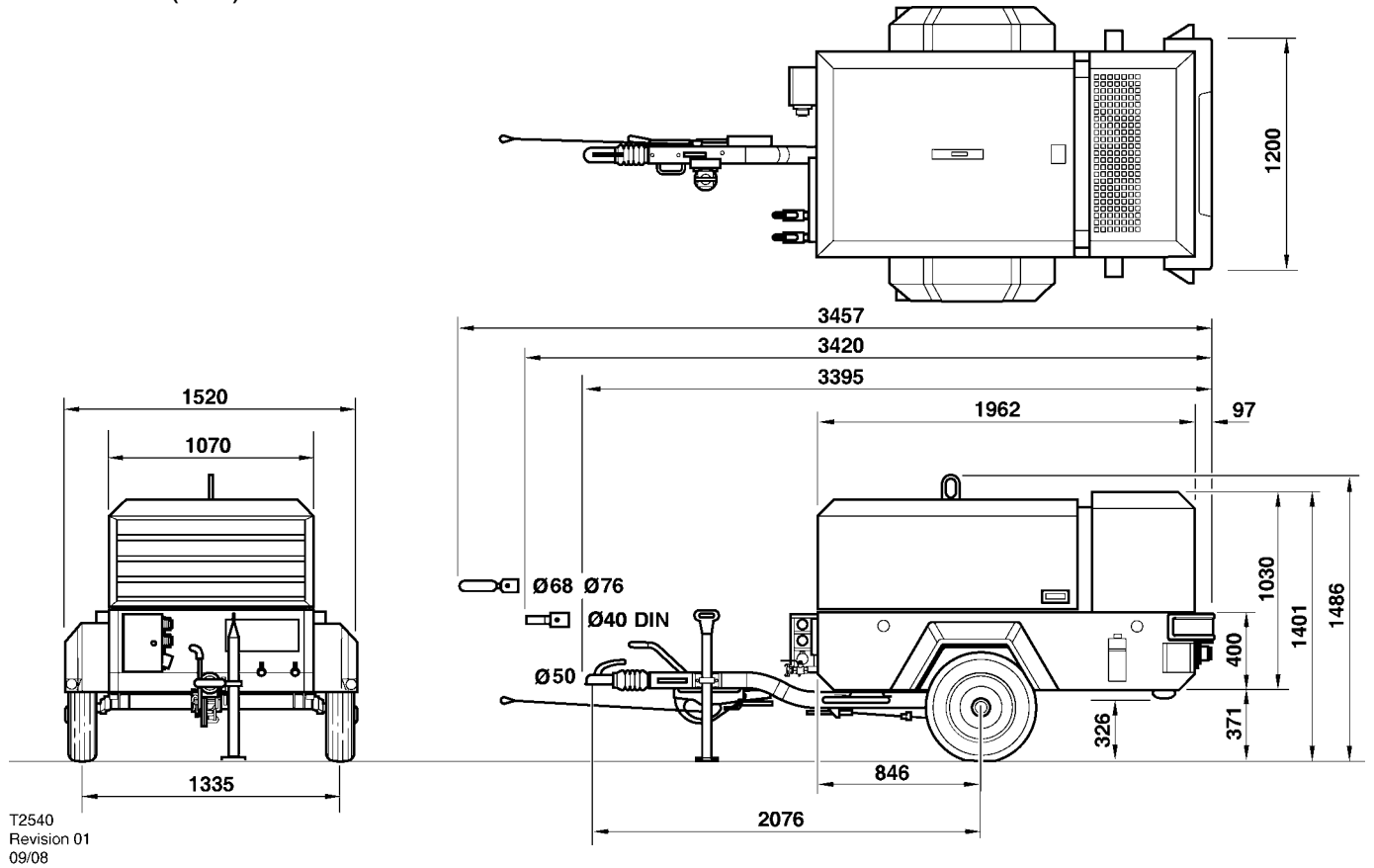

7/51 VARIABLE HEIGHT RUNNING GEAR
 Braked version (Knott)

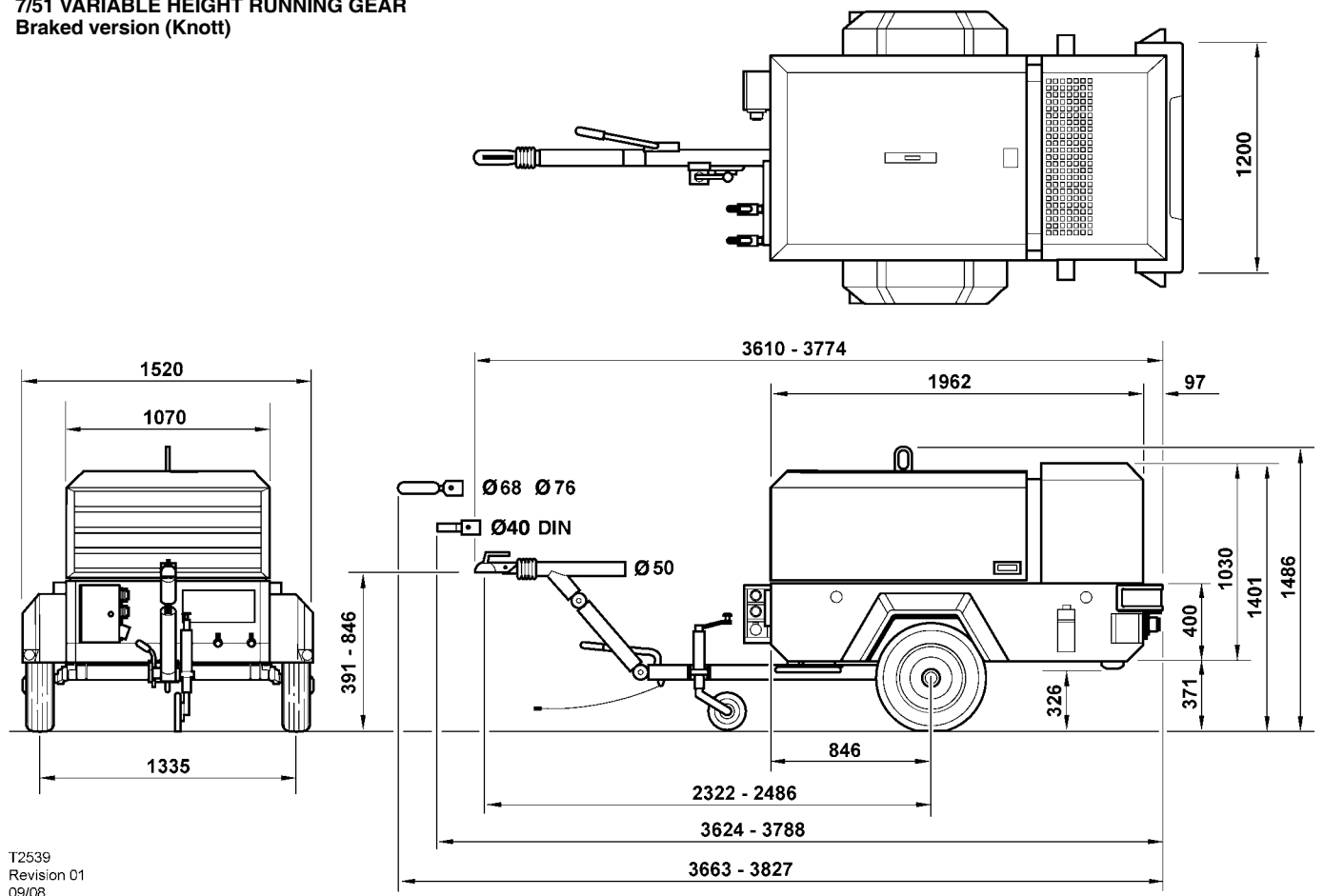

7/71, 12/56 FIXED HEIGHT RUNNING GEAR
Braked version

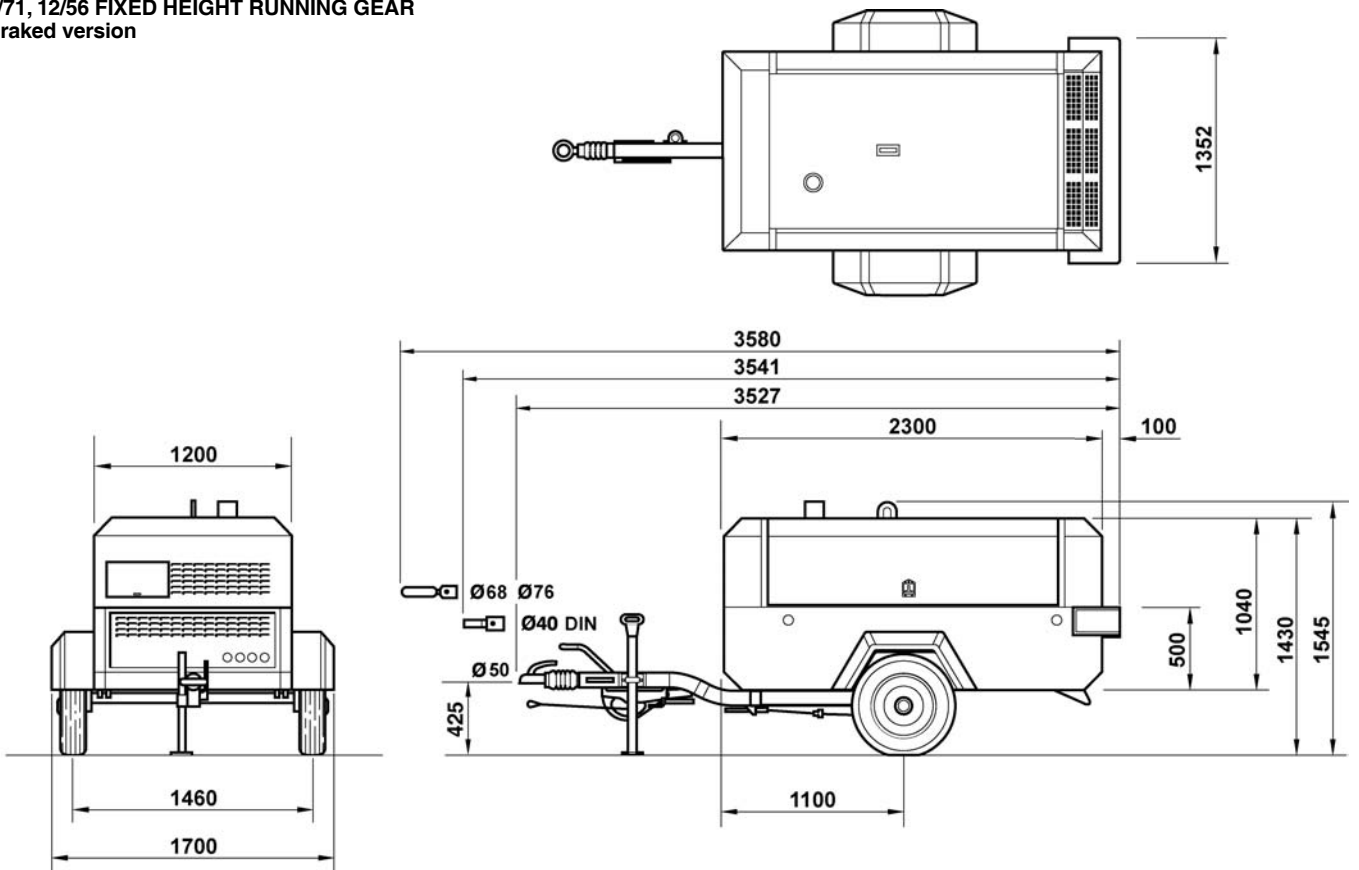

T1812
 Revision 02
 09/08

7/71, 12/56 VARIABLE HEIGHT RUNNING GEAR
Braked version

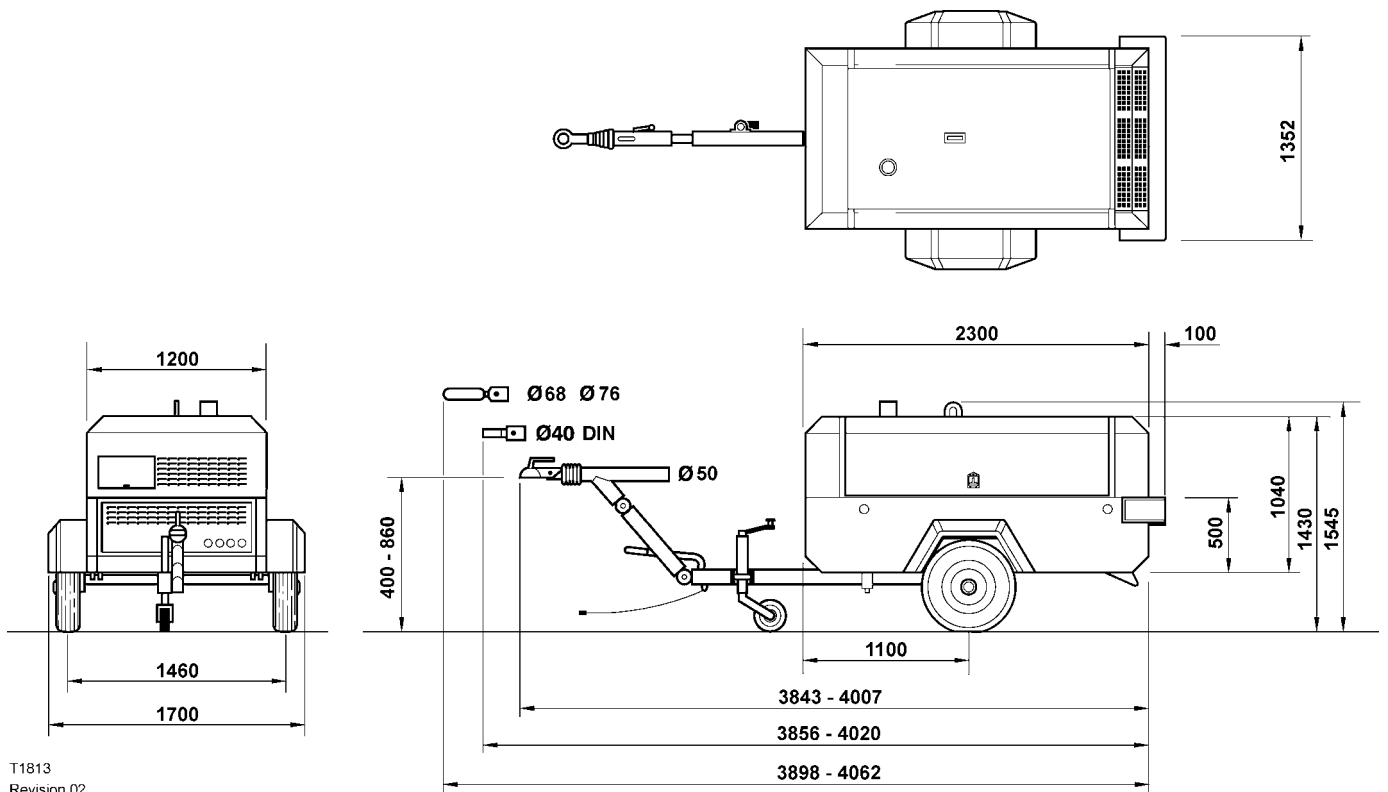

T1813
 Revision 02
 09/08

COMPRESSOR

Actual free air delivery. (7/51)	5,0 m ³ min ⁻¹ (175 CFM)
Actual free air delivery. (7/71)	7,1 m ³ min ⁻¹ (250 CFM)
Actual free air delivery. (12/56)	5,6 m ³ min ⁻¹ (200 CFM)
Normal operating discharge pressure. (7/51, 7/71)	7 bar (100 PSI)
Normal operating discharge pressure. (12/56)	12 bar (175 PSI)
Maximum allowable pressure. (7/51, 7/71)	8,6 bar (125 PSI)
Maximum allowable pressure. (12/56)	13 bar (190 PSI)
Safety valve setting. (7/51, 7/71)	10 bar (145 PSI)
Safety valve setting. (12/56)	13,5 bar (200 PSI)
Maximum pressure ratio (absolute). (7/51, 7/71)	7,5 : 1
Maximum pressure ratio (absolute). (12/56)	11,5 : 1
Operating ambient temperature. Whisperised Standard	-10°C TO +46°C (14°F TO 115°F) -10°C TO +52°C (14°F TO 126°F)
Maximum discharge temperature.	120°C (248°F)
Cooling system.	Oil injection
Oil capacity. (7/51)	12 litres (3,2 US GAL)
Oil capacity. (7/71, 12/56)	12,5 litres (3,3 US GAL)
Maximum oil system temperature.	120°C (248°F)
Maximum oil system pressure. (7/51, 7/71)	8,6 bar (125 PSI)
Maximum oil system pressure. (12/56)	13 bar (190 PSI)

LUBRICATING OIL SPECIFICATION

(for the specified ambient temperatures).

ABOVE -23°C(-9°F)

Recommended: Pro-Tec™
Approved: SAE 10W, API CF-4/CG-4

BELOW -23°C(-9°F)

Mandatory: IR Performance 500

Ingersoll-Rand Pro-Tec™ compressor fluid is factory-fitted, for use at all ambient temperatures above -23°C (-9°F).

NOTE: Warranty may be extended only by continuous use of Pro-Tec™ and Ingersoll-Rand oil filters and separators.

No other oil/fluids are compatible with Pro-Tec™

No other oils/fluids should be mixed with Pro-Tec™ because the resulting mixture could cause damage to the airend.

In the event that Pro-Tec™ is not available and / or the end user needs to use an approved single grade engine oil, the complete system including separator / receiver, cooler and pipework must be flushed clear of the first fill fluid and new Ingersoll-Rand oil filters installed. When this has been completed, the following oils are approved:

- for ambient temperatures above -23°C (-9°F), SAE 10W, API CF-4/CG-4
- for ambient temperatures below -23°C (-9°F), I-R Performance 500 only.

Safety data sheets can be obtained on request from the lubricant supplier.

For temperatures outside the specified ambient range, consult Ingersoll-Rand.

**ENGINE
7/51**

Type/model.	Ingersoll-Rand 4IR18NE-2
Number of cylinders.	4
Oil capacity.	9,5 litres (2,5 US GAL)
Speed at full load.	2400 revs min ⁻¹
Speed at idle.	1600 revs min ⁻¹
Electrical system.	12V negative earth
Power available at 2400 revs min ⁻¹	50,2kW (67,3 HP)
Fuel tank capacity	50 litres (13,2 US GAL)
Oil specification	Refer engine section
Coolant capacity	11 litres (2,9 US GAL)

**ENGINE
7/71, 12/56**

Type/model.	Ingersoll-Rand 4IR18TE
Number of cylinders.	4
Oil capacity.	10,5 litres (2,8 US GAL)
Speed at full load.	2300 revs min ⁻¹
Speed at idle.	1700 revs min ⁻¹
Electrical system.	12V negative earth
Power available at 2400 revs min ⁻¹	59,2kW (79,4 HP)
Fuel tank capacity	118 litres (31,2 US GAL)
Oil specification	Refer engine section
Coolant capacity	11 litres (2,9 US GAL)

**SOUND LEVEL DATA ('W' model)
7/51**

A) To Pneuop code PN8NTC2.

Equivalent continuous sound pressure level.*

. Rated load 84 dB(A)

(Operator position :-1m from machine)

Sound power level (84/533/EEC) 98 dB(A)

B) In compliance with 86/188/EEC.

Average sound pressure level at 10m

to 79/113/EEC.* 70 dB(A)

(*Machine only :- at maximum load in open site conditions)

**SOUND LEVEL DATA ('W' model)
7/71, 12/56**

A) To Pneuop code PN8NTC2.

Equivalent continuous sound pressure level.*

. Rated load 83 dB(A)

(Operator position :-1m from machine)

Sound power level (84/533/EEC) 99 dB(A)

B) In compliance with 86/188/EEC.

Average sound pressure level at 10m

to 79/113/EEC.* 71 dB(A)

(*Machine only :- at maximum load in open site conditions)

**FIXED HEIGHT RUNNING GEAR
Braked version (KNOTT)
7/51**

Shipping weight. 1010kg (2227 lbs)

Maximum weight. 1200kg (2646 lbs)

Maximum horizontal towing force. 1233 kgf (2720 lbs)

Maximum vertical coupling load
(nose weight). 100 kgf (220 lbs)**VARIABLE HEIGHT RUNNING GEAR
Braked version (KNOTT)
7/51**

Shipping weight. 1060kg (2337 lbs)

Maximum weight. 1200kg (2646 lbs)

Maximum horizontal towing force. 1233 kgf (2720 lbs)

Maximum vertical coupling load
(nose weight). 100 kgf (220 lbs)**FIXED HEIGHT RUNNING GEAR
Braked version (KNOTT)
7/71, 12/56**

Shipping weight. 1387kg (3058 lbs)

Maximum weight. 1600kg (3520 lbs)

Maximum horizontal towing force. 1578 kgf (3479 lbs)

Maximum vertical coupling load
(nose weight). 100 kgf (220 lbs)**VARIABLE HEIGHT RUNNING GEAR
Braked version (KNOTT)
7/71, 12/56**

Shipping weight. 1430kg (3153 lbs)

Maximum weight. 1600kg (3520 lbs)

Maximum horizontal towing force. 1578 kgf (3479 lbs)

Maximum vertical coupling load
(nose weight). 100 kgf (220 lbs)**WHEELS AND TYRES (KNOTT)**Number of wheels.
7/51 2 x 4¹/₂ JNumber of wheels.
7/71, 12/56 2 x 5¹/₂ JTyre size.
7/51 155 R13Tyre size.
7/71, 12/56 185 R14Tyre pressure.
7/51 2,9 bar (42 PSI)Tyre pressure.
7/71, 12/56 4,5 bar (65 PSI)

<p><i>Further information may be obtained by request through Ingersoll-Rand customer services department.</i></p>

COMMISSIONING

Upon receipt of the unit, and prior to putting it into service, it is important to adhere strictly to the instructions given below in *PRIOR TO STARTING*.

Ensure that the operator reads and *understands* the decals and consults the manuals before maintenance or operation.

Ensure that the position of the *emergency stop* device is known and recognised by its markings. Ensure that it is functioning correctly and that the method of operation is known.

Running gear drawbar – Machines are shipped to some areas with the drawbar removed. Fitting involves four nuts / bolts to secure the drawbar to the axle and two bolts to fit the drawbar to the front of the machine with the saddle and spacer block.

Support the front of the machine, fit the wheel chocks to stop the machine moving and attach the drawbar. Refer to the torque value table in the *MAINTENANCE* section of this manual for the correct torque values.

CAUTION:

This is a safety critical procedure. Double check the torque settings after assembly

Fit the propstand and coupling. Remove the supports and set the machine level.

Before towing the unit, ensure that the tyre pressures are correct (refer to the *GENERAL INFORMATION* section of this manual) and that the handbrake is functioning correctly (refer to the *MAINTENANCE* section of this manual). Before towing the unit during the hours of darkness, ensure that the lights are functioning correctly (where fitted).

Ensure that all transport and packing materials are discarded.

Ensure that the correct fork lift truck slots or marked lifting / tie down points are used whenever the machine is lifted or transported.

When selecting the working position of the machine ensure that there is sufficient clearance for ventilation and exhaust requirements, observing any specified minimum dimensions (to walls, floors etc.).

Adequate clearance needs to be allowed around and above the machine to permit safe access for specified maintenance tasks.

Ensure that the machine is positioned securely and on a stable foundation. Any risk of movement should be removed by suitable means, especially to avoid strain on any rigid discharge piping.

Attach the battery cables to the battery(s) ensuring that they are tightened securely. Attach the negative cable before attaching the positive cable.

WARNING: All air pressure equipment installed in or connected to the machine must have safe working pressure ratings of at least the machine rated pressure, and materials compatible with the compressor lubricant (refer to the *GENERAL INFORMATION* section).

WARNING: If more than one compressor is connected to one common downstream plant, effective check valves and isolation valves must be fitted and controlled by work procedures, so that one machine cannot accidentally be pressurised / over pressurised by another.

WARNING: If flexible discharge hoses are to carry more than 7 bar pressure then it is recommended that safety retaining wires are used on the hoses.

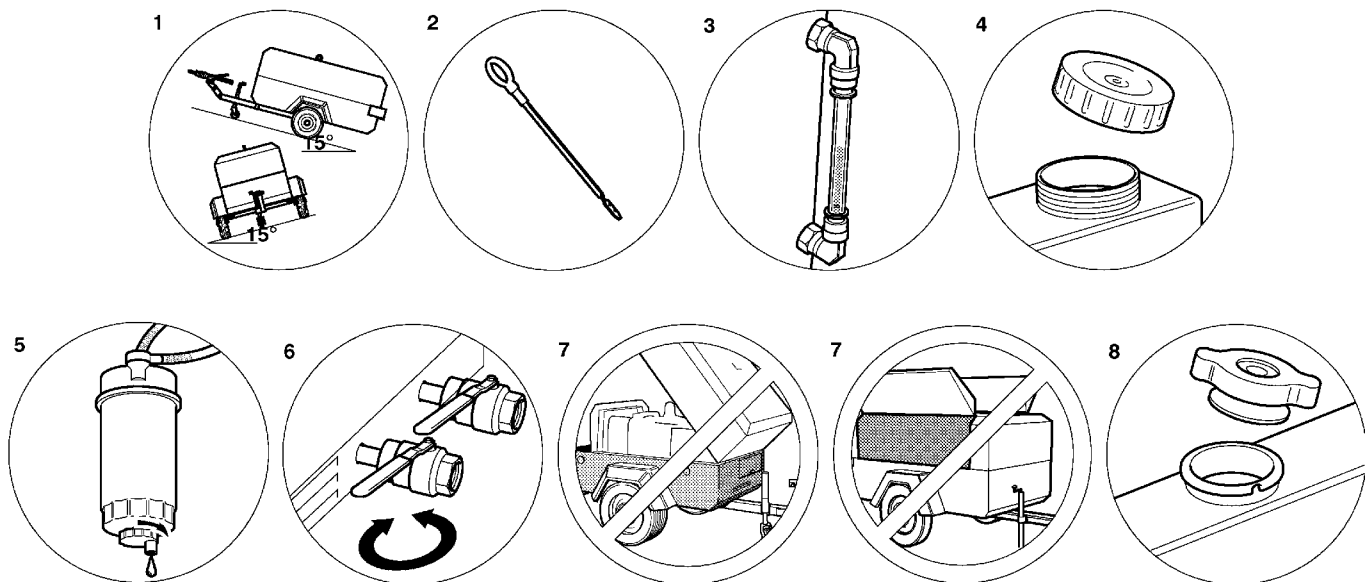

T1816
Revision 00
07/00

PRIOR TO STARTING

1. Place the unit in a position that is as level as possible. The design of the unit permits a 15 degree lengthways and sideways limit on out of level operation. It is the engine, not the compressor, that is the limiting factor.

When the unit has to be operated out of level, it is important to keep the engine oil level near the high level mark (with the unit level).

CAUTION: Do not overfill either the engine or the compressor with oil.

2. Check the engine lubrication oil in accordance with the operating instructions in the *Engine Operator's Manual*.

3. Check the compressor oil level in the sight glass located on the separator tank.

4. Check the diesel fuel level. A good rule is to top up at the end of each working day. This prevents condensation from occurring in the tank.

CAUTION: Use only a No. 2-D diesel fuel oil with a minimum octane number of 45 and a sulphur content not greater than 0,5%.

CAUTION: When refueling:-

- . switch off the engine.
- . do not smoke.
- . extinguish all naked lights.
- . do not allow the fuel to come into contact with hot surfaces.
- . wear personal protective equipment.

5. Drain the fuel filter water separator of water, ensuring that any released fuel is safely contained.

6. Open the service valve(s) to ensure that all pressure is relieved from the system. Close the service valve(s).

7. CAUTION: Do not operate the machine with the canopy/doors in the open position as this may cause overheating and operators to be exposed to high noise levels.

8. Check the radiator coolant level (with the unit level).

Check the air restriction indicator(s). Refer to the *MAINTENANCE* section of this manual.

When starting or operating the machine in temperatures below or approaching 0°C, ensure that the operation of the regulation system, the unloader valve, the safety valve, and the engine are not impaired by ice or snow, and that all inlet and outlet pipes and ducts are clear of ice and snow.

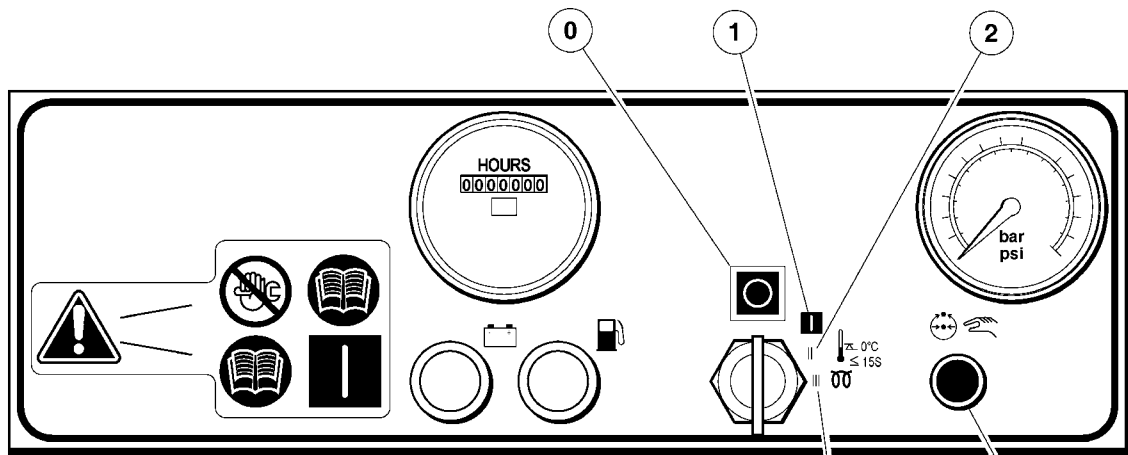

7/51

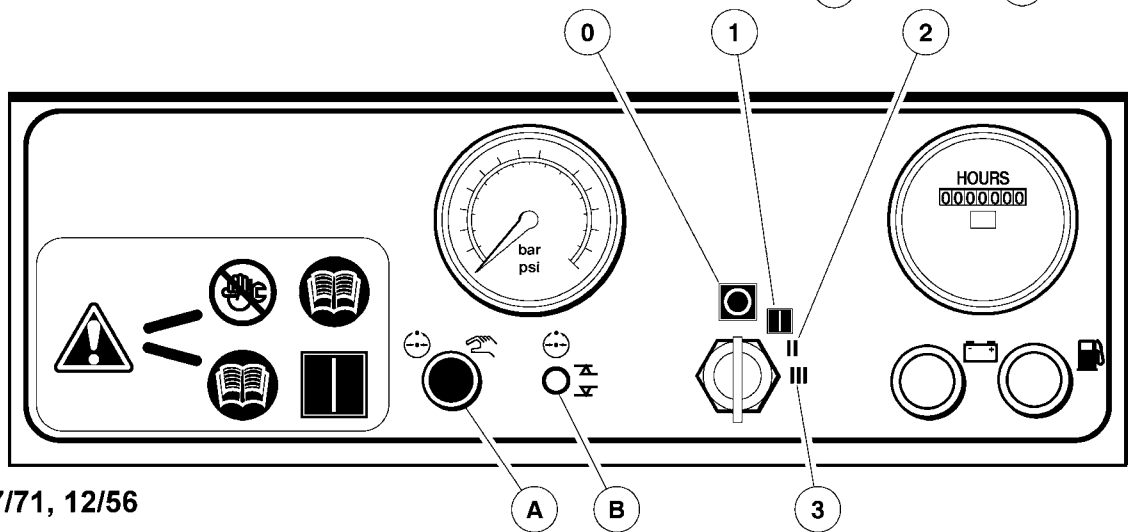

7/71, 12/56

T2412
Revision 00
09/08

STARTING THE MACHINE

WARNING: Under no circumstances should volatile liquids such as Ether be used for starting this machine.

All normal starting functions are incorporated in the key operated switch.

- Turn the key switch to position 2 and hold for max 15 seconds to allow the air inlet heater to reach working temperature.
- Turn the key switch to position 3 (engine start position).
- Release to position 2 when the engine starts.
- Release to position 1 when the alternator charge light is extinguished.

At temperatures below 0°C or if there is difficulty starting first time:

- Open the service valve fully, with no hose connected.
- Complete starting sequence above.
- Close service valve as soon as engine runs freely.
- Do not allow machine to run for long periods with service valve open.
- Allow the engine to reach operating temperature. Then press button (A) when fitted (Option on 7/51, standard on 7/71, 12/56).
- At this point in the operation of the machine it is safe to apply full load to the engine.

NOTE: Wear hearing protection at all times when the engine is started with the service valve open and air is flowing from the valve.

DUAL PRESSURE WHEN FITTED

Machines which operate in excess of 7 bar can optionally be fitted with a dual pressure switch (B). This switch selects between 7 bar and the machine rated pressure, cfm remains nominally constant.

Starting and stopping are unaffected by the selection and during normal running the selector switch may be safely operated. Precaution must be taken to ensure that downstream equipment is rated to suit the available pressure.

The pressure gauge indicates which setting has been selected.

STOPPING THE MACHINE

- . Close the service valve.
- . Allow the machine to run unloaded for a short period of time to reduce the engine temperature.
- . Turn the start switch to the 0 (off) position.

NOTE: As soon as the engine stops, the automatic blowdown valve will relieve all pressure from the system.

If the automatic blowdown valve fails to operate, then pressure must be relieved from the system by means of the service valve(s).

CAUTION: Never allow the machine to stand idle with pressure in the system.

EMERGENCY STOPPING

In the event that the unit has to be stopped in an emergency, **TURN THE KEY SWITCH LOCATED ON THE INSTRUMENT PANEL TO THE 0 (OFF) POSITION.**

RE-STARTING AFTER AN EMERGENCY

If the machine has been switched off because of a machine malfunction, then identify and correct the fault before attempting to re-start.

If the machine has been switched off for reasons of safety, then ensure that the machine can be operated safely before re-starting.

Refer to the *PRIOR TO STARTING* and *STARTING THE UNIT* instructions earlier in this section before re-starting the machine.

MONITORING DURING OPERATION

Should any of the safety shut-down conditions occur, the unit will stop. These are:

- . Low engine oil pressure
- . High air discharge temperature
- . High engine water temperature
- . Alternator drive belt failure.
- . Low engine fuel level.

CAUTION: To ensure an adequate flow of oil to the compressor at low temperature, never allow the discharge pressure to fall below 3,5 bar.

DECOMMISSIONING

When the machine is to be permanently decommissioned or dismantled, it is important to ensure that all hazard risks are either eliminated or notified to the recipient of the machine. In particular:-

- . Do not destroy batteries or components containing asbestos without containing the materials safely.
- . Do not dispose of any pressure vessel that is not clearly marked with its relevant data plate information or rendered unusable by drilling, cutting etc.
- . Do not allow lubricants or coolants to be released into land surfaces or drains.
- . Do not dispose of a complete machine without documentation relating to instructions for its use.

31 OPERATING INSTRUCTIONS

Small Electronic Control Unit (SECU)

Display Panel

The SECU display panel is arranged as shown below. A description of each diagnostic indicator is as follows:

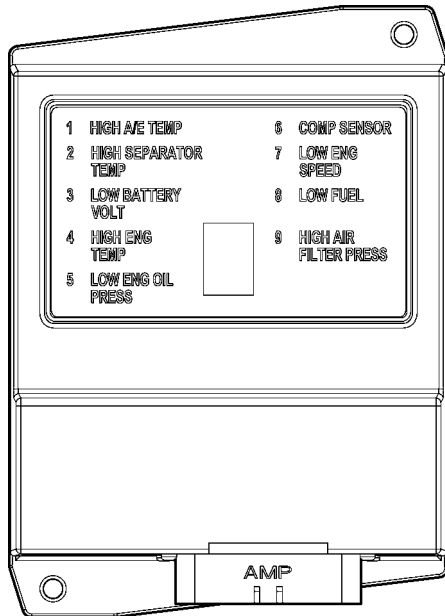

1. **High A/E Temp:** Indicates shutdown due to high compressor temperature.

2. **High Separator Temp:** Indicates shutdown due to high temperature at separator tank discharge.

3. **Low Battery Voltage:** Alarm indicator. Indicates battery or charging system requires service.

4. **High Engine Coolant Temp:** Indicates shutdown due to high engine water temperature.

5. **Low Engine Oil Pressure:** Indicates shutdown due to low engine oil pressure.

6. **Compressor Sensor Failure:** Indicates pressure sensor malfunction. Compressor will not start.

7. **Low Engine Speed:** Indicates shutdown due to low engine speed.

8. **Low Fuel Level:** Indicates shutdown due to low fuel level. (Optional)

9. **Restricted Air Filter:** Alarm indicator. Indicates engine/compressor air inlet filters need service. (Optional).

A. **Engine Communication Error:** Engine Model was not recognized. Compressor will start and operate with a 1700–2300 rpm range.

C. **CAN Communication Error:** CAN communication failure.

C. Could be also displayed when EmergencyStop Button (optional) remains pressed before Starting. Engine will not start (crank) in that case.

E. **Generator Enable Switch Error:** Generator enable switch on the control panel remains ON before starting. See also section Options – generator option. Engine will not start (crank) at that case.

Normal Conditions:

–. **Center Bar Blinking:** Compressor is ready to start (no faults).

H. **Crank Signal Detected:** Displayed while start switch is in the pre-heat or crank position.

During SECU/power up, the 8 digit lights to check the display. Next the display will step through the 3 digit software revision number.

Engine Diagnostic Codes:

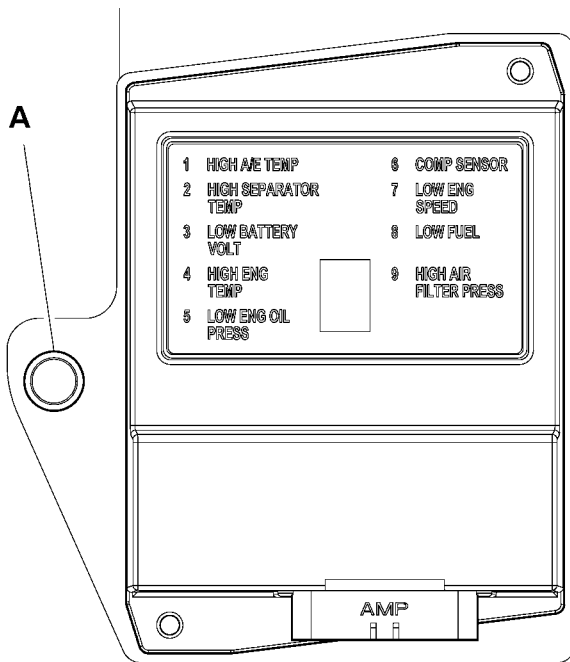

- Failure Flashes can be read on the Engine Failure Lamp when the on/off power switch is 'ON' or when the unit is running.
- The Engine Failure Lamp is located behind the front end panel (see figure).
- The Failure Lamp is illuminated for 2 seconds when the ECU is powered on.
- A lamp flash duration of 0.5 second is a 'Short' flash.
- A lamp flash duration of 1.5 seconds is a 'Long' flash.
- A failure flash sequence of '1 Long and 3 Short' would be displayed by flashing the lamp one time with a duration of 1.5 seconds and three times with a duration of 0.5 seconds.
- When two or more failures have occurred simultaneously, the failure lamp will pause for 3 seconds between flash sequences.
- Failure flash sequences continuously repeat with 3 second pauses between flash sequences until the failure is corrected.

A. – Engine Failure Lamp

Failure	Failure Flashes	Remark
Coolant temperature sensor failure	4 Short	
Speed sensor failure	6 Short	
Rack position sensor failure	7 Short	
Rack actuator failure	8 Short	
EGR valve failure	1 Long and 3 Short	
CSD solenoid valve failure	1 Long and 4 Short	
Main relay failure	1 Long and 6 Short	
Rack actuator relay failure	1 Long and 7 Short	
ECU temperature alarm	2 Long and 5 Short	ECU temp > 221°F
Coolant temperature alarm	3 Long and 6 Short	Coolant temp > 230°F
ECU failure	4 Long and 1 Short	

MAINTENANCE SCHEDULE							
	Initial 500 miles /850 km	Daily	Weekly	Monthly	3 Monthly. 250 hrs.	6 Monthly. 500 hrs	12 Monthly. 1000 hrs
Compressor Oil Level		C					
Engine Oil Level		C					
*Radiator Coolant Level		C					
Gauges/Lamps		C					
*Air Cleaner Service Indicators		C					
Fuel Tank (Fill at end of day)		C				D	
*Fuel/Water Separator Drain		C					
Oil Leaks		C					
Fuel Leaks		C					
Drain Water From Fuel Filters		D					
Coolant Leaks		C					
Radiator Filler Cap		C					
Air Cleaner Precleaner Dumps			C				
Fan/Alternator Belts			C				
Generator Drive Belt			C				
Battery Connections/Electrolyte			C				
Tire Pressure and Surface			C				
*Wheel Lug Nuts				C			
Hoses (Oil, Air, Intake, etc.)				C			
Automatic Shutdown System				C			
Air Cleaner System				C			
Compressor Oil Cooler Exterior				C			
*Engine Rad/Oil Cooler Exterior				C			
Fasteners, Guards					C		
Air Cleaner Elements						R/WI	

*Disregard if not appropriate for this particular machine.

(1) or 3000 miles/5000km whichever is the sooner

(2) or as defined by local or national legislation

C = Check (adjust, clean or replace as necessary)

CBT =check before towing.

CR = Check and report

D = Drain

G = Grease

R=Replace

T = Test

W I =or when indicated if earlier.

Refer to specific sections of the operator's manual for more information.

	Initial 500 miles /850 km	Daily	Weekly	Monthly	3 Monthly. 250 hrs.	6 Monthly. 500 hrs	12 Monthly. 1000 hrs	18 Monthly. 1500 hrs
*Fuel/Water Separator Element						R		
Compressor Oil Filter Element						R		
Compressor Oil						R		
Engine Oil Change						R		
Engine Oil Filter						R		
*Water Pump Grease.							R	
*Wheels (Bearings, Seals, etc.)						C		
*Engine Coolant						C	R	
Fuel Filter Element						R		
*Injection Nozzle Check								C
Shutdown Switch Settings							T	
Scavenger Orifice & Related Parts							C	
Oil Separator Element							R	
*Feed Pump Strainer Cleaning.							C	
Coolant Replacement							R	
*Valve Clearance Check							C	
Lights (running, brake, & turn)		CBT						
Pintle Eye Bolts		CBT						
*Brakes	C				C			
*Brake linkage	C							
Emergency stop		T						
Fasteners		C						
Running gear linkage				G				
Safety valve					C			
Running gear bolts(1)					C			

*Disregard if not appropriate for this particular machine.

(1) or 3000 miles/5000km whichever is the sooner

(2) or as defined by local or national legislation

C = Check (adjust, clean or replace as necessary)

CBT =check before towing.

CR = Check and report

D = Drain

G = Grease

R=Replace

T = Test

W I =or when indicated if earlier.

Refer to specific sections of the operator's manual for more information.

	Initial 500 miles /850 km	Daily	Weekly	Monthly	3 Monthly. 250 hrs.	6 Monthly. 500 hrs	12 Monthly. 1000 hrs
Scavenge line						C	
Pressure system						C	
Engine breather element							C
Pressure gauge							C
Pressure regulator							C
Separator tank (2) exterior							CR
Lubricator (Fill)		C					

	2 Yrs	4 Yrs	6 Yrs				
Safety valve	C						
Hoses		R					
Separator tank (2) interior			C				

*Disregard if not appropriate for this particular machine.

(1) or 3000 miles/5000km whichever is the sooner

(2) or as defined by local or national legislation

C = Check (adjust, clean or replace as necessary)

CBT =check before towing.

CR = Check and report

D = Drain

G = Grease

R=Replace

T = Test

W I =or when indicated if earlier.

Refer to specific sections of the operator's manual for more information.

ROUTINE MAINTENANCE

This section refers to the various components which require periodic maintenance and replacement.

The *SERVICE/MAINTENANCE CHART* indicates the various components' descriptions and the intervals when maintenance has to take place. Oil capacities, etc., can be found in the *GENERAL INFORMATION* section of this manual.

For any specification or specific requirement on service or preventative maintenance for the engine, refer to the *Engine Manufacturer's Manual*.

Compressed air can be dangerous if incorrectly handled. Before doing any work on the unit, ensure that all pressure is vented from the system and that the machine cannot be started accidentally.

If the automatic blowdown fails to operate, then pressure must be gradually relieved by operating the manual blowdown valve. Suitable personal protective equipment should be worn.

Ensure that maintenance personnel are adequately trained, competent and have read the Maintenance Manuals.

Prior to attempting any maintenance work, ensure that:-

- . all air pressure is fully discharged and isolated from the system. If the automatic blowdown valve is used for this purpose, then allow enough time for it to complete the operation.
- . the discharge pipe / manifold area is depressurised by opening the discharge valve, whilst keeping clear of any airflow from it.

MINIMUM PRESSURE VALVE – WHEN FITTED

NOTE: Pressure will always remain in the part of the system between the minimum pressure valve and the discharge valve after operation of the auto blowdown valve.

This pressure must be relieved by carefully:

- (a) Disconnecting any downstream equipment.
- (b) Opening the discharge valve to atmosphere.

(Use hearing protection if necessary).

. the machine cannot be started accidentally or otherwise, by posting warning signs and/or fitting appropriate anti-start devices.

. all residual electrical power sources (mains and battery) are isolated.

Prior to opening or removing panels or covers to work *inside* a machine, ensure that:-

. anyone entering the machine is aware of the reduced level of protection and the additional hazards, including hot surfaces and intermittently moving parts.

. the machine cannot be started accidentally or otherwise, by posting warning signs and/or fitting appropriate anti-start devices.

Prior to attempting any maintenance work on a *running* machine, ensure that:-

. the work carried out is limited to only those tasks which require the machine to run.

. the work carried out with safety protection devices disabled or removed is limited to only those tasks which require the machine to be running with safety protection devices disabled or removed.

. all hazards present are known (e.g. pressurised components, electrically live components, removed panels, covers and guards, extreme temperatures, inflow and outflow of air, intermittently moving parts, safety valve discharge etc.).

. appropriate personal protective equipment is worn.

. loose clothing, jewelry, long hair etc. is made safe.

. warning signs indicating that *Maintenance Work is in Progress* are posted in a position that can be clearly seen.

Upon completion of maintenance tasks and prior to returning the machine into service, ensure that:-

- . the machine is suitably tested.
- . all guards and safety protection devices are refitted.
- . all panels are replaced, canopy and doors closed.
- . hazardous materials are effectively contained and disposed of.

PROTECTIVE SHUTDOWN SYSTEM

Comprises:

- . Low engine oil pressure switch
- . High discharge air temperature switch
- . High engine water temperature switch
- . Alternator/drive belt failure circuit.
- . Low engine fuel level switch.

Low engine oil pressure switch.

At three month intervals, test the engine oil pressure switch circuit as follows:

- . Start the machine.

NOTE: Do not press the load button.

. Remove a wire from one terminal of the switch. The machine should shutdown.

At twelve month intervals, test the engine oil pressure switch as follows:

- . Remove the switch from the machine.
- . Connect it to an independent low pressure supply (either air or oil).
- . The switch should operate at 1,0 bar.
- . Refit the switch.

Temperature switch(es).

At three month intervals, test the temperature switch circuit(s) as follows:

- . Start the machine.

NOTE: Do not press the load button.

. Disconnect each switch in turn. The machine should shutdown.

. Re-connect the switch.

High discharge air temperature switch(es).

At twelve month intervals, test the air discharge temperature switch(es) by removing it from the machine and immersing in a bath of heated oil. The switch should operate at 120°C. Refit the switch.

High water temperature switch

At twelve month intervals, test the water temperature switch by removing it from the machine and immersing in a bath of heated oil. The switch should operate at 105°C. Refit the switch.

Alternator/drive belt failure circuit.

At twelve month intervals test the alternator drive belt failure circuit as follows:

- Remove the drive belt from the machine.
- Turn the key switch to position 1, the alternator charge light will illuminate.
- Turn the key switch to position 3 (engine start position).
- The machine should shutdown when the key switch is returned to position 1.

Low engine fuel level switch.

At three month intervals, test the low engine fuel level switch circuit as follows:

- Start the machine.

NOTE: Do not press the load button.

- Disconnect the switch, the machine should shutdown.
- Re-connect the switch.

At twelve month intervals, test the low engine fuel level switch by removing and operating the float manually.

CAUTION: Never remove or replace switches when the machine is running.

SCAVENGE LINE

The scavenge line runs from the combined orifice/drop tube in the separator tank, to the orifice fitting located in the aircend.

Examine the orifice, check valve and hoses at every service or in the event of oil carryover into the discharge air.

It is good preventative maintenance to check that the scavenge line and tube are clear of any obstruction each time the compressor lubricant is changed as any blockage will result in oil carryover into the discharge air.

COMPRESSOR OIL FILTER

Refer to the *MAINTENANCE CHART* in this section for the recommended servicing intervals.

Removal

WARNING: Do not remove the filter(s) without first making sure that the machine is stopped and the system has been completely relieved of all air pressure. (Refer to *STOPPING THE UNIT* in the *OPERATING INSTRUCTIONS* section of this manual).

Clean the exterior of the filter housing and remove the *spin-on* element by turning it in a counter-clockwise direction.

Inspection

Examine the filter element.

CAUTION: If there is any indication of the formation of varnishes, shellacs or lacquers on the filter element, it is a warning that the compressor lubricating and cooling oil has deteriorated and that it should be changed immediately. Refer to *LUBRICATION* later in this section.

Reassembly

Clean the filter gasket contact area and install the new element by screwing in a clockwise direction until the gasket makes contact with the filter housing. Tighten a further $\frac{1}{2}$ to $\frac{3}{4}$ of a revolution.

CAUTION: Start the machine (refer to *PRIOR TO STARTING* and *STARTING THE UNIT* in the *OPERATING INSTRUCTIONS* section of this manual) and check for leakage before the machine is put back into service.

COMPRESSOR OIL SEPARATOR ELEMENT

Normally the separator element will not require periodic maintenance provided that the air and oil filter elements are correctly maintained.

If, however, the element has to be replaced, then proceed as follows:

Removal

WARNING: Do not remove the filter(s) without first making sure that the machine is stopped and the system has been completely relieved of all air pressure. (Refer to *STOPPING THE UNIT* in the *OPERATING INSTRUCTIONS* section of this manual).

Disconnect all hoses and tubes from the separator tank cover plate. Remove the drop-tube from the separator tank cover plate and then remove the cover plate. Remove the separator element.

Inspection

Examine the filter element. Examine all hoses and tubes, and replace if necessary.

Reassembly

Thoroughly clean the orifice/drop tube and filter gasket contact area before reassembly. Install the new element.

WARNING
Do not remove the staple from the anti-static gasket on the separator element since it serves to ground any possible static build-up. Do not use gasket sealant since this will affect electrical conductance.

Reposition the cover plate, taking care not to damage the gasket, and replace the cover plate screws tightening in a *criss-cross* pattern to the recommended torque (refer to the *TORQUE SETTING TABLE* later in this section).

Engage the adaptor in the cover plate with the drop-tube integral with the filter, reconnect all hoses and tubes to the separator tank cover plate.

Replace the compressor oil (refer to *LUBRICATION* later in this section).

CAUTION: Start the machine (refer to *PRIOR TO STARTING* and *STARTING THE UNIT* in the *OPERATING INSTRUCTIONS* section of this manual) and check for leakage before the machine is put back into service.

COMPRESSOR OIL COOLER AND ENGINE RADIATOR

When grease, oil and dirt accumulate on the exterior surfaces of the oil cooler and radiator, the efficiency is impaired. It is recommended that each month the oil cooler and radiator be cleaned by directing a jet of compressed air, (carrying if possible a non-flammable cleaning solvent) over the exterior core of the cooler/radiator. This should remove any accumulation of oil, grease and dirt from the exterior core of the cooler so that the entire cooling area can radiate the heat of the lubricating and cooling oil/water into the air stream.

WARNING: Hot engine coolant and steam can cause injury. When adding coolant or antifreeze solution to the engine radiator, stop the engine at least one minute prior to releasing the radiator filler cap. Using a cloth to protect the hand, slowly release the filler cap, absorbing any released fluid with the cloth. Do not remove the filler cap until all excess fluid is released and the engine cooling system fully depressurised.

WARNING: Follow the instructions provided by the antifreeze supplier when adding or draining the antifreeze solution. It is advisable to wear personal protective equipment to prevent skin and eye contact with the antifreeze solution.

AIR FILTER ELEMENTS

The air filter should be inspected regularly (refer to the *SERVICE/MAINTENANCE CHART*) and the element replaced when the restriction indicator shows red or every 6 Months (500 hours), whichever comes first. The dust collector box(es) should be cleaned daily (more frequently in dusty operating conditions) and not allowed to become more than half full.

Removal

CAUTION: Never remove and replace element(s) when the machine is running.

Clean the exterior of the filter housing and remove the filter element by releasing the nut.

Inspection

Check for cracks, holes or any other damage to the element by holding it up to a light source, or by passing a lamp inside.

Check the seal at the end of the element and replace if any sign of damage is evident.

Reassembly

Assemble the new element into the filter housing ensuring that the seal seats properly.

Reset the restriction indicator by depressing the rubber diaphragm.

Assemble the dust collector box parts, ensuring that they are correctly positioned.

Before restarting the machine, check that all clamps are tight.

VENTILATION

Always check that the air inlets and outlets are clear of debris etc.

CAUTION: NEVER clean by blowing air inwards.

COOLING FAN DRIVE

Periodically check that the fan mounting bolts in the fan hub have not loosened. If, for any reason, it becomes necessary to remove the fan or re-tighten the fan mounting bolts, apply a good grade of commercially available thread locking compound to the bolt threads and tighten to the torque value shown in the *TORQUE SETTING TABLE* later in this section.

The fan belt(s) should be checked regularly for wear and correct tensioning.

FUEL SYSTEM

The fuel tank should be filled daily or every eight hours. To minimise condensation in the fuel tank(s), it is advisable to top up after the machine is shut down or at the end of each working day. At six month intervals drain any sediment or condensate that may have accumulated in the tank(s).

FUEL FILTER WATER SEPARATOR

If the fuel filter water separator contains a filter element it should be replaced at regular intervals (see the *SERVICE/MAINTENANCE CHART*).

HOSES

All components of the engine cooling air intake system should be checked periodically to keep the engine at peak efficiency.

At the recommended intervals, (see the *SERVICE/MAINTENANCE CHART*), inspect all of the intake lines to the air filter, and all flexible hoses used for air lines, oil lines and fuel lines.

Periodically inspect all pipework for cracks, leaks, etc. and replace immediately if damaged.

ELECTRICAL SYSTEM

WARNING: Always disconnect the battery cables before performing any maintenance or service.

39 MAINTENANCE

Inspect the safety shutdown system switches and the instrument panel relay contacts for evidence of arcing and pitting. Clean where necessary.

Check the mechanical action of the components.

Check the security of electrical terminals on the switches and relays i.e. nuts or screws loose, which may cause local hot spot oxidation.

Inspect the components and wiring for signs of overheating i.e. discolouration, charring of cables, deformation of parts, acrid smells and blistered paint.

BATTERY

Keep the battery terminals and cable clamps clean and lightly coated with petroleum jelly to prevent corrosion.

The retaining clamp should be kept tight enough to prevent the battery from moving.

PRESSURE SYSTEM

At 500 hour intervals it is necessary to inspect the external surfaces of the system (from the airend through to the discharge valve(s)) including hoses, tubes, tube fittings and the separator tank, for visible signs of impact damage, excessive corrosion, abrasion, tightness and chafing. Any suspect parts should be replaced before the machine is put back into service.

TYRES/TYRE PRESSURE

See the *GENERAL INFORMATION* section of this manual.

RUNNING GEAR/WHEELS

Check the wheel nut torque 20 miles (30 kilometres) after refitting the wheels. Refer to the *TORQUE SETTING TABLE* later in this section.

Lifting jacks should only be used under the axle.

The bolts securing the running gear to the chassis should be checked periodically for tightness (refer to the *SERVICE/MAINTENANCE CHART* for frequency) and re-tightened where necessary. Refer to the *TORQUE SETTING TABLE* later in this section.

BRAKES

Check and adjust the brake linkage at 500 miles (850Km) then every 3000 miles (5000Km) or 3 months (whichever is the sooner) to compensate for any stretch of the adjustable cables. Check and adjust the wheel brakes to compensate for wear.

Adjusting the overrun braking system (KNOTT Running Gear)

1: Preparation

Jack up the machine

Disengage the handbrake lever [1].

Fully extend the draw bar [2] on the overrun braking system.

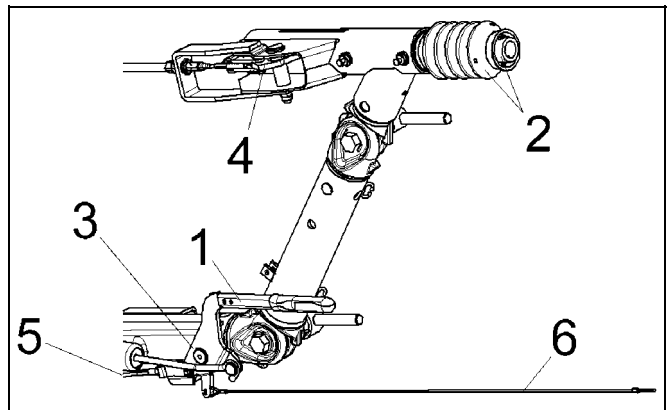

- 1 Handbrake lever
- 2 Draw bar and bellows
- 3 Handbrake lever pivot
- 4 Transmission lever
- 5 Brake cable
- 6 Breakaway Cable

Requirements:

During the adjustment procedure always start with the wheel brakes.

Always rotate the wheel in the direction of forward movement.

Ensure that an M10 safety screw is fitted to the handbrake pivot.

The brake actuators must not be pre-tensioned – if necessary loosen the brake linkage [7] on the brake equalisation assembly [8].

Check that brake actuators and cables [11] operate smoothly.

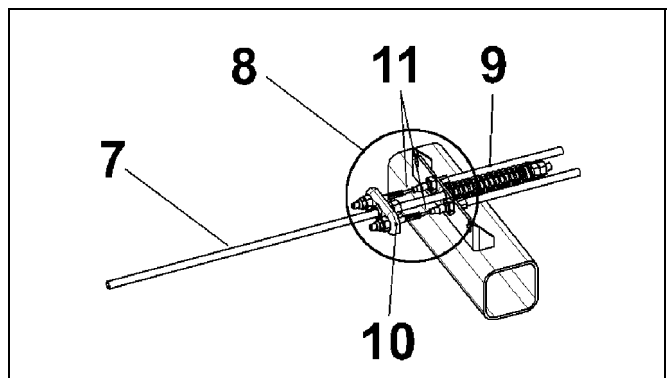

- 7 Brake linkage
- 8 Equalisation assembly
- 9 Compression spring
- 10 Equaliser plate
- 11 Cable

CAUTION

The compression spring [9] must only be lightly pre-tensioned and when operating must never touch the axle tube. Never adjust the brakes at the brake linkage [7].

2. Brake Shoe Adjustment

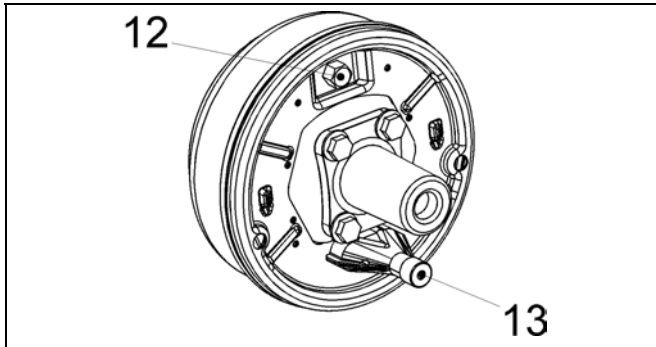

12 Adjusting screw	
13 Cable entry	
Width across flats of adjusting screw [12]	
Brake size	Key width
160x35 / 200x50	SW 17
250x40	SW 19
300x60	SW 22

Tighten adjusting screw [12] clockwise until the wheel locks.

Loosen adjusting screw [12] anti-clockwise (approx. 1/2 turn) until the wheel can be moved freely.

Slight dragging noises that do not impede the free movement of the wheel are permissible.

This adjustment procedure must be carried out as described on both wheel brakes.

When the brake has been adjusted accurately the actuating distance is approximately 5–8mm on the cable [11]

3: Compensator assembly adjustment

Variable Height models

Fit an M10 safety screw to the handbrake pivot.

Disconnect the handbrake cable [5] at one end.

Pre-adjust brake linkage [7] lengthways (a little play is permissible) and re-insert the cable [5], adjusting it to give a small amount of play.

Remove the M10 safety screw from the handbrake pivot.

All Models

Engage the handbrake lever [1] and check that the position of the equaliser plate [10] is at right angles to the pulling direction. If necessary correct the position of the equaliser plate [10] on the cables [11].

The compression spring [9] must only be slightly pre-tensioned and when engaged must not touch the axle tube.

4: Brake linkage adjustment

Adjust the brake linkage [7] lengthways without pre-tension and without play in the transmission lever [4].

Readjustment

Engage the handbrake lever [1] forcefully a number of times to set the brake.

Check the alignment of the equalisation assembly [8], this should be at right angles to the pulling direction

Check the play in the brake linkage [7]

If necessary adjust the brake linkage [7] again without play and without pre-tensioning

There must still be a little play in cable [5] (Variable Height Only)

Check the position of the hand brake lever [1]. The start of resistance should be approximately 10–15mm above the horizontal position.

Check that the wheels move freely when the handbrake is disengaged.

Final test

Check the fastenings on the transmission system (cables, brake equalisation system and linkage).

Check the handbrake cable [5] for a small amount of play and adjust if necessary (Variable height only)

Check the compression spring [9] for pre-tensioning.

Test run

If necessary carry out 2–3 test brake actions.

Test brake action

Check the play in brake linkage [7] and if necessary adjust the length of brake linkage [7] until there is no play.

Apply the handbrake while rolling the machine forward, travel of the handbrake lever up to 2/3 of maximum is allowed.

Re-adjusting the overrun braking system (KNOTT Running Gear)

Re-adjustment of the wheel brakes will compensate for brake lining wear. Follow the procedure described in 2: Brake Shoe Adjustment.

Check the play in the brake linkage [7] and re-adjust if necessary.

Important

Check the brake actuators and cables [11]. The brake actuators must not be pre-tensioned.

Excessive operation of the handbrake lever, which may have been caused by worn brake linings, must not be corrected by re-adjusting (shortening) the brake linkage [7]

Re-adjustment

The handbrake lever [1] should be engaged forcefully several times to set the braking system.

Check the setting of the brake equalisation assembly [8], which should be at right angles to the pulling direction.

Check the play in the brake linkage [7] again, ensuring that there is no play in the brake linkage and that it is adjusted without pre-tension

Check the position of the hand brake lever [1], cable [5] (with little play) and the compression spring [9] (only slight pre-tension). The start of resistance of the handbrake lever should be approximately 10–15mm above the horizontal position.

Final test

Check the fastenings on the transmission system (cables, brake equalisation system and linkage)

Apply the handbrake while rolling the machine forward, travel of the handbrake lever up to 2/3 of maximum is allowed.

Check the handbrake cable [5] for a small amount of play and adjust if necessary (Variable height only)

Check the compression spring [9] for slight pre-tensioning.

CAUTION: Check the wheel nut torque 20 miles (30 kilometres) after refitting the wheels (Refer to the TORQUE SETTING TABLE later in this section).

41 MAINTENANCE

LUBRICATION

The engine is initially supplied with engine oil sufficient for a nominal period of operation (for more information, consult the Engine section of this manual).

CAUTION: Always check the oil levels before a new machine is put into service.

If, for any reason, the unit has been drained, it must be re-filled with new oil before it is put into operation.

ENGINE LUBRICATING OIL

The engine oil should be changed at the engine manufacturer's recommended intervals. Refer to the Engine section of this manual.

ENGINE LUBRICATING OIL SPECIFICATION

Refer to the Engine section of this manual.

ENGINE OIL FILTER ELEMENT

The engine oil filter element should be changed at the engine manufacturer's recommended intervals. Refer to the Engine section of this manual.

COMPRESSOR LUBRICATING OIL

Refer to the *SERVICE/MAINTENANCE CHART* in this section for service intervals.

NOTE: If the machine has been operating under adverse conditions, or has suffered long shutdown periods, then more frequent service intervals will be required.

WARNING: DO NOT, under any circumstances, remove any drain plugs or the oil filler plug from the compressor lubricating and cooling system without first making sure that the machine is stopped and the system has been completely relieved of all air pressure (refer to *STOPPING THE UNIT* in the *OPERATING INSTRUCTIONS* section of this manual).

Completely drain the receiver/separator system including the piping and oil cooler by removing the drain plug(s) and collecting the used oil in a suitable container.

Replace the drain plug(s) ensuring that each one is secure.

NOTE: If the oil is drained immediately after the machine has been running, then most of the sediment will be in suspension and will therefore drain more readily.

CAUTION: Some oil mixtures are incompatible and result in the formation of varnishes, shellacs or lacquers which may be insoluble.

NOTE: Always specify INGERSOLL-RAND Pro-Tec™ oil for use at all ambient temperatures above -23°C.

COMPRESSOR OIL FILTER ELEMENT

Refer to the *SERVICE / MAINTENANCE CHART* in this section for service intervals.

RUNNING GEAR WHEEL BEARINGS

Wheel bearings should be packed with grease every 6 months. The type of grease used should conform to specification *MIL-G-10924*.

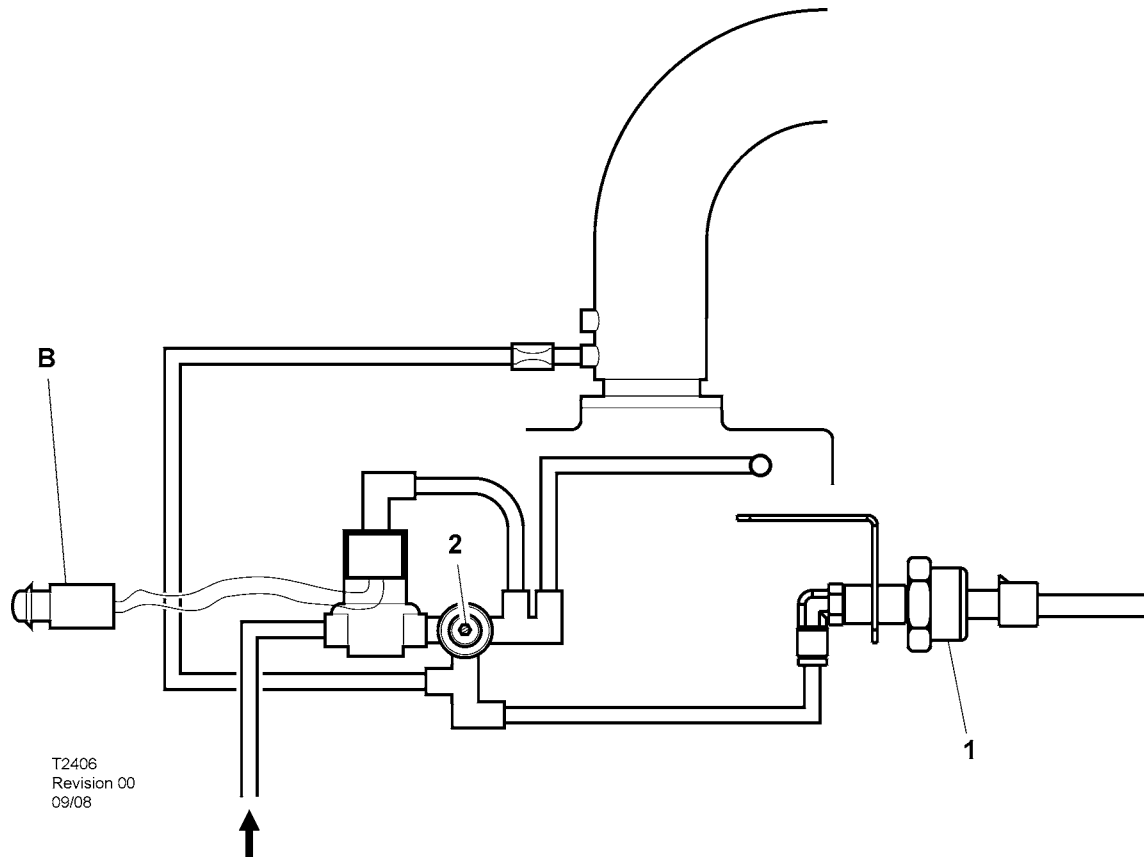

SPEED AND PRESSURE REGULATION ADJUSTMENT

Normally, regulation requires no adjusting, but if correct adjustment is lost, proceed as follows:

Refer to the diagram above.

- 1: Pressure transducer
- 2: Adjusting screw
- B: Push After Warm-up button

At the Pressure Regulator loosen the jam nut and turn screw counterclockwise until tension is no longer felt at the screw. Then, turn screw clockwise one full turn.

Close the service valve.

Start the machine (Refer to *STARTING INSTRUCTIONS* in the *OPERATING INSTRUCTIONS* section of this manual).

Press button (B) – Push After Warm-up (Refer to *STARTING INSTRUCTIONS* in the *OPERATING INSTRUCTIONS* section of this manual) when fitted (standard for 7/71, 12/56, optional for 7/51).

The unit should speed up and then unload (and drop back to IDLE). With the unit unloaded (service valve is fully closed), turn the adjusting screw on the pressure regulator clockwise until the discharge pressure gauge indicates 8.6 bar (7/51, 7/71) or 13 bar (12/56).

Open the service valve fully. Check the engine speed up to full RPM, then adjust the service valve to maintain 7 bar (7/51, 7/71) or 12 bar (12/56) – see pressure gauge on the control panel.

If the engine speed falls down before 7 bar (7/51, 7/71) or 12 bar (12/56) pressure is attained, then turn the adjusting screw clockwise to increase the pressure. Optimum adjustment is achieved when the engine speed just falls down from full speed and the pressure gauge reads 7.2 bar (7/51, 7/71) or 12.2 bar (12/56).

Lock adjusting screw by the jam nut.

Close the service valve. The engine will slow to idle speed.

CAUTION: Never allow the idle pressure to exceed 8,6bar (7/51, 7/71) or 13 bar (12/56) on the pressure gauge, otherwise the safety valve will operate.

TORQUE VALUES

	ft lbf	Nm
Airend to engine	29-35	39-47
Air filter to bracket	16-20	22-27
Autella clamp to exhaust	9-11	12-15
Baffle to frame	9-11	12-15
Blowdown solenoid valve	21-26	28-35
Discharge manifold to frame	29-35	39-47
Drive pins to engine flywheel	57-69	77-93
Drop Leg	53-63	72-85
Engine/airend to chassis	54-58	73-78
Euro-Loc adaptor to separator tank	58-67	78-91
Exhaust flange to manifold	17-21	23-28

	ft lbf	Nm
Fan guard	9-11	12-15
Fan to hub	12-15	16-20
Lifting bail bracket to engine	29-35	39-47
Oil pipe (-12jic)	71-88	96-119
Radiator/Cooler to baffle	9-11	12-15
Running gear front to chassis	63-69	82-93
Running gear rear to chassis	63-69	82-93
Running gear drawbar to axle	29-35	39-47
Separator tank cover	40-50	54-68
Separator tank to frame	18-22	24-30
Service pipe (-20jic)	106-133	143-180
Sight glass	40-50	54-68
Wheel nuts	62-70	85-95

COMPRESSOR LUBRICATION

Portable Compressor Fluid Chart

Refer to these charts for correct compressor fluid required. Note that the selection of fluid is dependent on the design operating pressure of the machine and the ambient temperature expected to be encountered before the next oil change.

Design Operating Pressure	Ambient Temperature	Specification
100 psi to 300 psi	-10°F to 125°F (-23°C to 52°C)	IR Pro-Tec™ Mil -PRF 2104G SAE 10W
100 psi to 300 psi	-40°F to 125°F (-40°C to 52°C)	IR Performance 500 Mil-L-46167
350 psi	-10°F to 125°F (-23°C to 52°C) 65°F to 125°F (18°C to 52°C) -40°F to 65°F (-40°C to 18°C)	IR XHP 505 IR XHP1001 IR Performance 500 Mil-L-46167
500 psi	50°F to 125°F (10°C to 52°C) 10°F to 65°F (-12°C to 18°C) below 10°F (-12°C)	IR XHP1001 IR XHP 505 Consult Factory

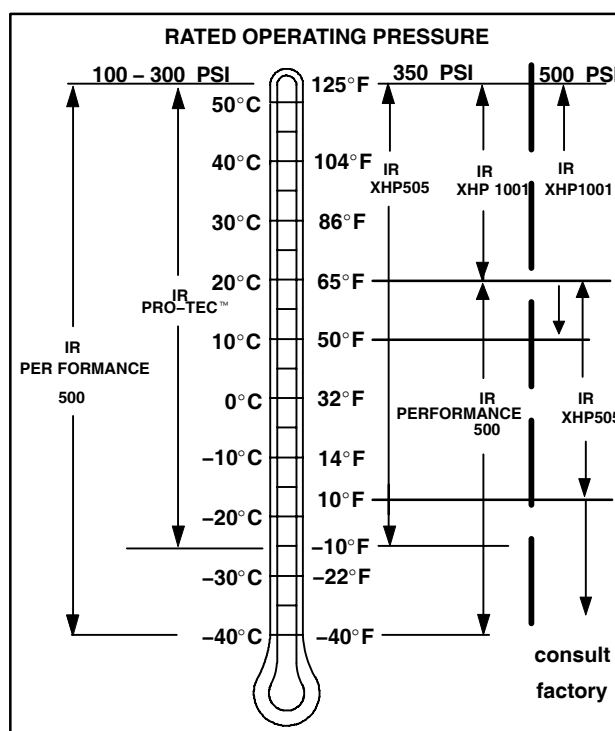

Recommended Ingersoll-Rand Fluids – Use of these fluids with original IR filters can extend airend warranty. Refer to operator's manual warranty section for details or contact your IR representative.

Recommended Fluid	3.8 Litre	19.0 Litre	208.2 Litre
IR Pro-Tec™	36899698	36899706	36899714
IR XHP 505		35365188	35365170
IR Performance 500	35382928	35382936	35382944
IR XHP1001		35612738	35300516

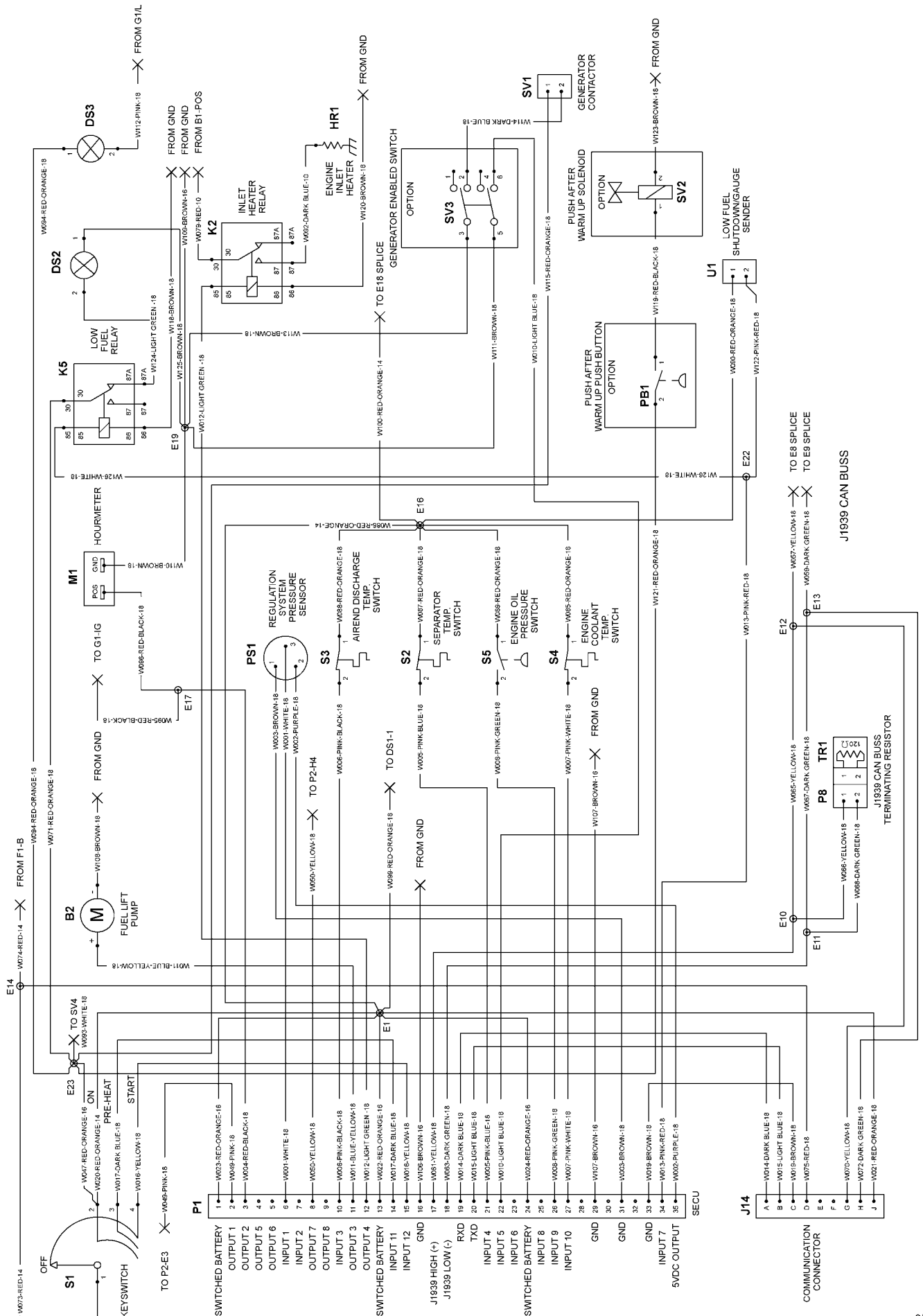

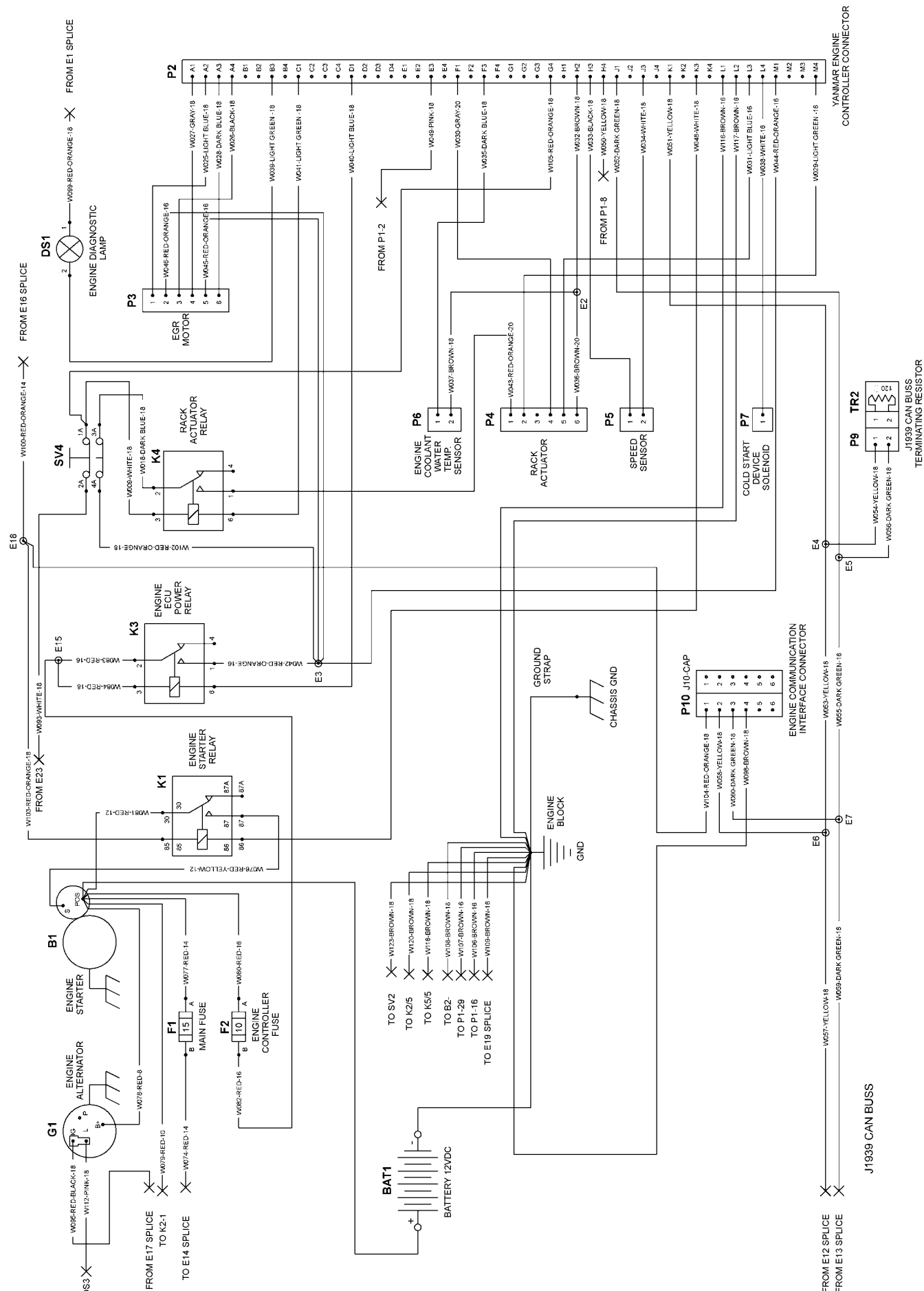

7/51

23321807-3
09/08

KEY

B1	Engine Starter	P4	Rack Actuator
B2	Fuel Lift Pump	P5	Speed Sensor
BAT1	Battery 12VDC	P6	Engine Coolant Temperature Sensor
DS1	Engine Diagnostic Lamp	P7	Cold Start Device Solenoid
DS2	Low Fuel Lamp	P8/TR1	CAN BUSS Terminating Resistor
DS3	No Charge Lamp	P9/TR2	CAN BUSS Terminating Resistor
F1	Main Fuse	P10	Engine ECU Interface Communication Connector
F2	Engine ECU Fuse	PB1	Push After Warm up Button (Option on 7/51, standard on 7/71, 12/56)
G1	Engine Alternator	PS1	Regulation System Pressure Sensor
HR1	Engine Inlet Heater	S1	Keyswitch
J14	Communication Connector	S2	Separator Temperature Switch
K1	Engine Starter Relay	S3	Airend Discharge Temperature Switch
K2	Inlet Heater Relay	S4	Engine Coolant temperature switch
K3	Engine ECU Power Relay	S5	Engine Oil Pressure Switch
K4	Rack Actuator Relay	SV1	Generator Contactor
K5	Low Fuel Relay	SV2	Push After Warm up Solenoid (Option on 7/51, standard on 7/71, 12/56)
M1	Hourmeter	SV3	Generator Enable Switch (Option)
P1	SECU – Small Electronic Control Unit	SV4	Emergency Stop Button (Option)
P2	Yanmar Engine ECU	U1	Low Fuel Shutdown Switch
P3	EGR Valve		

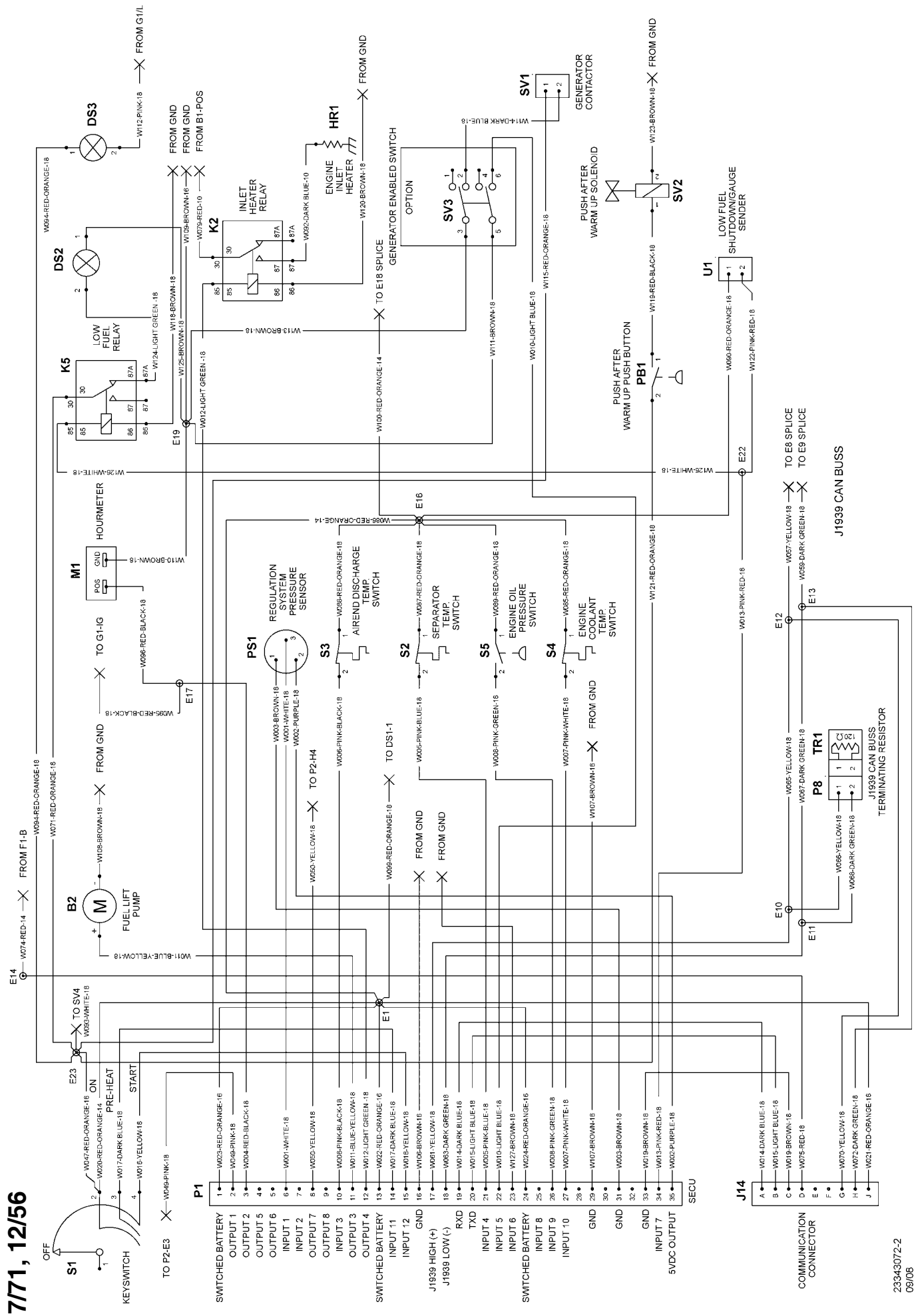

7/71, 12/56

23343072-2
09/08

7/71, 12/56

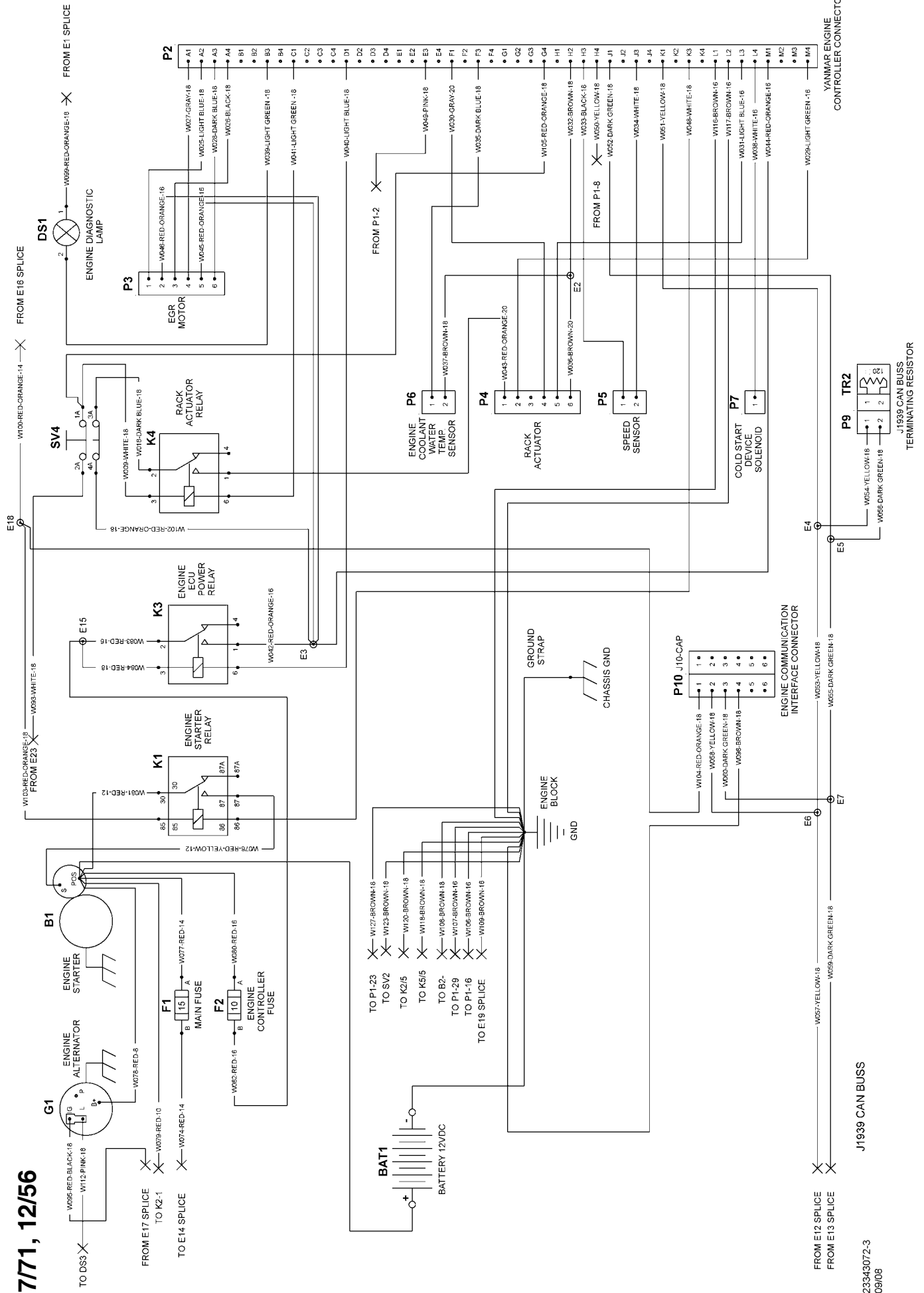

KEY

B1	Engine Starter	P4	Rack Actuator
B2	Fuel Lift Pump	P5	Speed Sensor
BAT1	Battery 12VDC	P6	Engine Coolant Temperature Sensor
DS1	Engine Diagnostic Lamp	P7	Cold Start Device Solenoid
DS2	Low Fuel Lamp	P8/TR1	CAN BUSS Terminating Resistor
DS3	No Charge Lamp	P9/TR2	CAN BUSS Terminating Resistor
F1	Main Fuse	P10	Engine ECU Interface Communication Connector
F2	Engine ECU Fuse	PB1	Push After Warm up Button (Option on 7/51, standard on 7/71, 12/56)
G1	Engine Alternator	PS1	Regulation System Pressure Sensor
HR1	Engine Inlet Heater	S1	Keyswitch
J14	Communication Connector	S2	Separator Temperature Switch
K1	Engine Starter Relay	S3	Airend Discharge Temperature Switch
K2	Inlet Heater Relay	S4	Engine Coolant temperature switch
K3	Engine ECU Power Relay	S5	Engine Oil Pressure Switch
K4	Rack Actuator Relay	SV1	Generator Contactor
K5	Low Fuel Relay	SV2	Push After Warm up Solenoid (Option on 7/51, standard on 7/71, 12/56)
M1	Hourmeter	SV3	Generator Enable Switch (Option)
P1	SECU – Small Electronic Control Unit	SV4	Emergency Stop Button (Option)
P2	Yanmar Engine ECU	U1	Low Fuel Shutdown Switch
P3	EGR Valve		

51 ELECTRICAL SYSTEM

SCHEMATIC DIAGRAM FOR EUROPEAN CE LIGHTING SYSTEM – 7 PINS

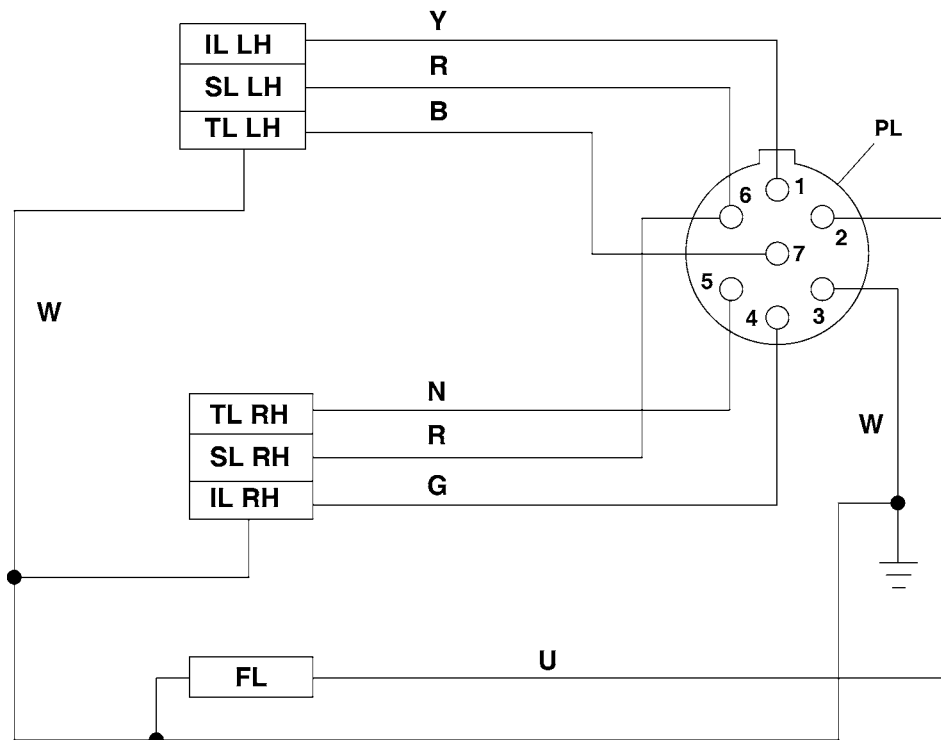

T2404
Revision 00
09/08

KEY

IL LH	Indicator light – left hand	B	Black
IL RH	Indicator light – right hand	G	Green
FL	Fog light	K	Pink
SL LH	Stop light – left hand	N	Brown
SL RH	Stop light – right hand	O	Orange
TL LH	Tail light – left hand	P	Purple
TL RH	Tail light – right hand	R	Red
PL	Plug	S	Grey
		U	Blue
		W	White
		Y	Yellow

SCHEMATIC DIAGRAM FOR EUROPEAN CE LIGHTING SYSTEM – 13 PINS REVERSE LIGHT

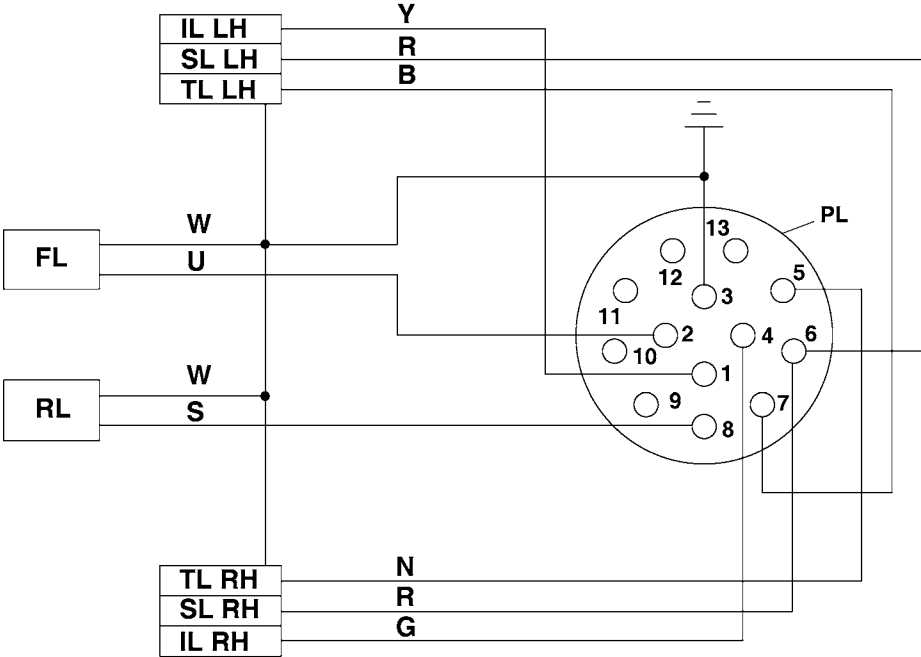

T2405
Revision 00
09/08

KEY

IL LH	Indicator light – left hand	B	Black
IL RH	Indicator light – right hand	G	Green
FL	Fog light	K	Pink
RL	Reverse light	N	Brown
SL LH	Stop light – left hand	O	Orange
SL RH	Stop light – right hand	P	Purple
TL LH	Tail light – left hand	R	Red
TL RH	Tail light – right hand	S	Grey
PL	Plug	U	Blue
		W	White
		Y	Yellow

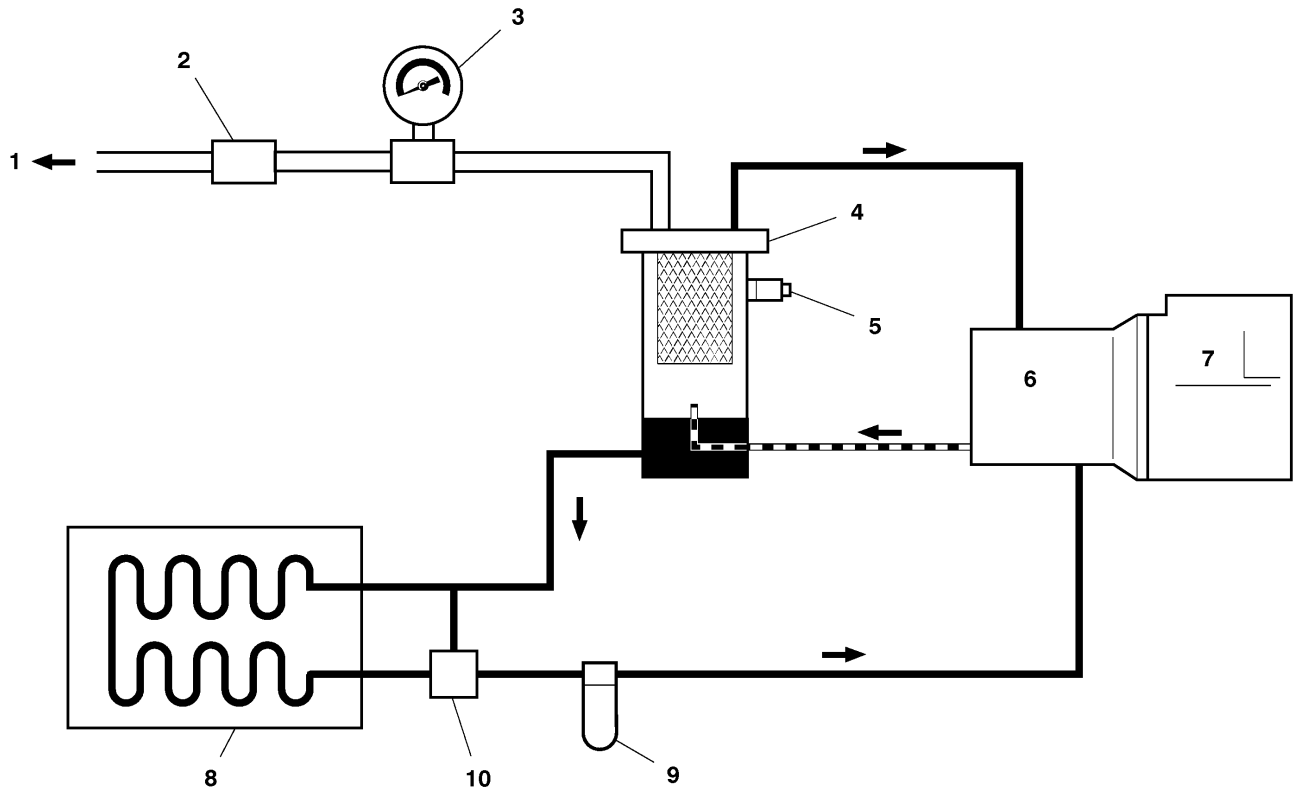

T1815
Revision 00
07/00

KEY

1	Air discharge	8	Oil cooler
2	Sonic orifice (restricts flow)	9	Oil filter
3	Pressure gauge	10	Thermostatic valve (Where fitted)
4	Separator tank		
5	Safety valve		
6	Compressor		
7	Engine		

	Air
	Oil
	Air/oil

FAULT	CAUSE	REMEDY
Engine fails to start.	<i>Low battery charge.</i>	Check the fan belt tension, battery and cable connections.
	<i>Bad earth connection.</i>	Check the earth cables, clean as required.
	<i>Loose connection.</i>	Locate and make the connection good.
	<i>Fuel starvation.</i>	Check the fuel level and fuel system components. Replace the fuel filter if necessary.
	<i>Relay failed.</i>	Replace the relay.
	<i>Engine control not in 'run' position.</i>	Check the pressure transducer.
Engine starts but stalls when the switch returns to position I.	<i>Electrical fault</i>	Test the electrical circuits.
	<i>Low engine oil pressure.</i>	Check the oil level and the oil filter(s).
	<i>Faulty relay</i>	Check the relays.
	<i>Faulty key-switch</i>	Check the key-switch.
Engine starts but will not run or engine shuts down prematurely.	<i>Electrical fault.</i>	Test the electrical circuits.
	<i>Low engine oil pressure.</i>	Check the oil level and oil filter(s).
	<i>Safety shut-down system in operation.</i>	Check the safety shut-down switches.
	<i>Fuel starvation.</i>	Check the fuel level and fuel system components. Replace the fuel filter if necessary.
	<i>Switch failure.</i>	Test the switches.
	<i>High compressor oil temperature.</i>	Check the compressor oil level and oil cooler. Check the fan drive.
	<i>Water present in fuel system.</i>	Check the water separator and clean if required.
	<i>Faulty relay.</i>	Check the relay in the holder and replace if necessary.
Engine Overheats.	<i>Reduced cooling air from fan.</i>	Check the fan and the drive belts. Check for any obstruction inside the cowl.
Engine speed too high.	<i>Faulty regulator valve.</i>	Check the regulation system.

FAULT	CAUSE	REMEDY
Engine speed too low.	<i>Incorrect throttle arm setting.</i>	Check the throttle setting.
	<i>Blocked fuel filter.</i>	Check and replace if necessary.
	<i>Blocked air filter.</i>	Check and replace the element if necessary.
	<i>Faulty regulator valve.</i>	Check the regulation system.
	<i>Premature unloading.</i>	Check the regulation and the operation of the pressure transducer.
Excessive vibration.	<i>Engine speed too low.</i>	See "Engine speed too low"
Refer also to the engine section of this manual and the engine diagnostic codes.		
Air discharge capacity too low.	<i>Engine speed too low.</i>	Check the pressure transducer and air filter(s).
	<i>Blocked air cleaner.</i>	Check the restriction indicators and replace the element(s) if necessary.
	<i>High pressure air escaping.</i>	Check for leaks.
	<i>Incorrectly set regulation system.</i>	Reset the regulation system. Refer to <i>SPEED AND PRESSURE REGULATION ADJUSTMENT</i> in the <i>MAINTENANCE</i> section of this manual.
Compressor overheats.	<i>Low oil level.</i>	Top up the oil level and check for leaks.
	<i>Dirty or blocked oil cooler.</i>	Clean the oil cooler fins.
	<i>Incorrect grade of oil.</i>	Use Ingersoll-Rand recommended oil.
	<i>Recirculation of cooling air.</i>	Move the machine to avoid recirculation.
	<i>Faulty temperature switch.</i>	Check the operation of the switch and replace if necessary.
	<i>Reduced cooling air from fan.</i>	Check the fan and the drive belts. Check for any obstruction inside the fan cowl.
Excessive oil present in the discharge air.	<i>Blocked scavenge line.</i>	Check the scavenge line, drop tube and orifice. Clean and replace.
	<i>Perforated separator element.</i>	Replace the separator element.
	<i>Pressure in the system is too low.</i>	Check the minimum pressure valve or sonic orifice.

FAULT	CAUSE	REMEDY
Safety valve operates.	<i>Operating pressure too high.</i>	Check the setting and operation of the regulator valve piping.
	<i>Incorrect setting of the regulator.</i>	Adjust the regulator.
	<i>Faulty regulator.</i>	Replace the regulator.
	<i>Inlet valve set incorrectly.</i>	Refer to <i>SPEED AND PRESSURE REGULATION ADJUSTMENT</i> in the <i>MAINTENANCE</i> section of this manual.
	<i>Loose pipe/hose connections.</i>	Check all pipe/hose connections.
	<i>Faulty safety valve.</i>	Check the relieving pressure. Replace the safety valve if faulty. DO NOT ATTEMPT A REPAIR.

FAULT	CAUSE	REMEDY
Oil is forced back into the air filter.	<i>Incorrect stopping procedure used</i>	Always employ the correct stopping procedure. Close the discharge valve and allow the machine to run on idle before stopping.
	<i>Faulty inlet valve.</i>	Check for free operation of the inlet valve(s).
	<i>Faulty discharge check valve.</i>	Remove the valve from the discharge pipe and check the operation.
Machine goes to full pressure when started.	<i>Inlet valve set incorrectly.</i>	Refer to <i>SPEED AND PRESSURE REGULATION ADJUSTMENT</i> in the <i>MAINTENANCE</i> section of this manual.
Machine fails to load when the load button is pressed.	<i>Faulty load solenoid.</i>	Replace the solenoid. Check the electrical circuit by feeling for movement whilst depressing the load button.

Engine Diagnostic Codes:

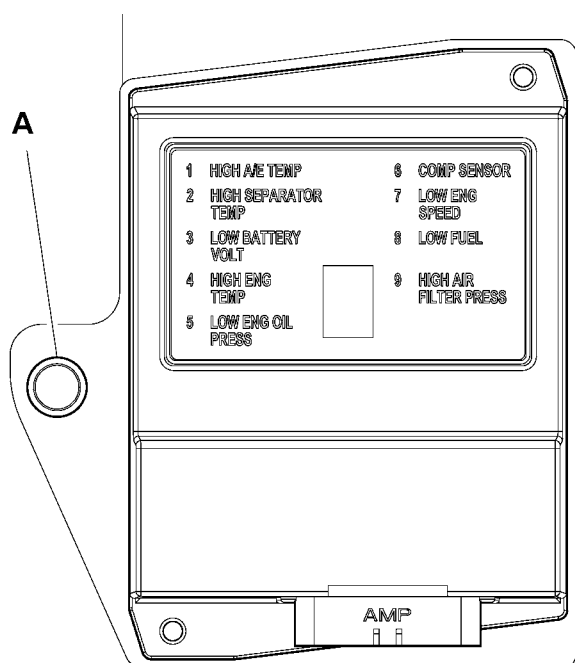

- Failure Flashes can be read on the Engine Failure Lamp when the on/off power switch is 'ON' or when the unit is running.
- The Engine Failure Lamp is located behind the front end panel (see figure).
- The Failure Lamp is illuminated for 2 seconds when the ECU is powered on.
- A lamp flash duration of 0.5 second is a 'Short' flash.
- A lamp flash duration of 1.5 seconds is a 'Long' flash.
- A failure flash sequence of '1 Long and 3 Short' would be displayed by flashing the lamp one time with a duration of 1.5 seconds and three times with a duration of 0.5 seconds.
- When two or more failures have occurred simultaneously, the failure lamp will pause for 3 seconds between flash sequences.
- Failure flash sequences continuously repeat with 3 second pauses between flash sequences until the failure is corrected.

A. – Engine Failure Lamp

Failure	Failure Flashes	Remark
Coolant temperature sensor failure	4 Short	
Speed sensor failure	6 Short	
Rack position sensor failure	7 Short	
Rack actuator failure	8 Short	
EGR valve failure	1 Long and 3 Short	
CSD solenoid valve failure	1 Long and 4 Short	
Main relay failure	1 Long and 6 Short	
Rack actuator relay failure	1 Long and 7 Short	
ECU temperature alarm	2 Long and 5 Short	ECU temp > 221°F
Coolant temperature alarm	3 Long and 6 Short	Coolant temp > 230°F
ECU failure	4 Long and 1 Short	

LUBRICATOR

SAFETY

WARNING: Ensure that the lubricator filler cap is re-tightened correctly after replenishing with oil.

WARNING: Do not replenish the lubricator oil, or service the lubricator without first making sure that the machine is stopped and the system has been completely relieved of all air pressure (Refer to *STOPPING THE UNIT* in the *OPERATING INSTRUCTIONS* section of this manual).

CAUTION: If the nylon tubes to the lubricator are disconnected then ensure that each tube is re-connected in its original location.

GENERAL INFORMATION

Oil capacity: 2 litres

Oil specification:
Refer to the *Tool Manufacturer's Manual*.

OPERATING INSTRUCTIONS

COMMISSIONING

Check the lubricator oil level and fill as necessary.

PRIOR TO STARTING

Check the lubricator oil level and replenish as necessary.

MAINTENANCE

Check the lubricator oil level and replenish as necessary.

FAULT FINDING

FAULT	CAUSE	REMEDY
No oil flow.	<i>Incorrect connection.</i>	Reverse the nylon tube connections to the lubricator.

GENERATOR

(WDG)

SAFETY

Refer to the *SAFETY SECTION* in this manual.

GENERAL INFORMATION

Rated output.	4,8 kW @ 0,8 Power factor (PF) lagging
Rated voltage	110V 1ph or 230V 1ph or 230V 3ph or 400V 3ph + 230V 1ph @ 3000 revs min ⁻¹
Voltage regulation	+/- 6%
Maximum continuous output	6 kVA @ 0,8 PF
Rotor type	Brushless (110/230V 1ph)
Rotor type	Rotating armature with sliprings (230V 3ph / 400V 3ph + 230V 1ph)
De-rating factors at 0.8 pf continuous load:	
<i>Air in temp 20° C</i>	Continuous
<i>Air in temp 30° C</i>	5,7 KVA @ 0.8 p.f continuous
<i>Air in temp 46° C</i>	4,5 KVA @ 0.8 p.f continuous

De-rating factors for intermittent load:

Air in temp 20–35° C, 55 mins/hr @ 0.8, 5 mins off load
Air in temp 35–40° C, 50 mins/hr @ 0.8, 10 mins off load
Air in temp 40° C + ,45 mins/hr @ 0.8, 15 mins off load

Socket outlets:

<i>110V 1ph & 230V 1ph</i>	1 x 32 amperes 2 x 16 amperes
<i>230V 3ph</i>	1 x 16 amperes
<i>400V 3ph + 230V 1ph</i>	400V 3ph = 1 x 16 amperes 230V 1ph = 2 x 16 amperes

Earth leakage protection is provided by a single residual current device. Miniature circuit breakers (MCB) are fitted to provide both overcurrent and short circuit protection for the generator.

Each socket outlet is protected by a spring loaded weather-proof cover.

OPERATING INSTRUCTIONS

A mode selector switch is provided to switch the machine between compressor and generator mode.

CAUTION: Do not start or stop the machine with the compressor/generatormode switch in the **Generator** position. Engine starting/cranking is prevented in this mode – see also “Operating Instructions – SECU section”.

When the switch is moved to Generator position, the machine control unit SECU will give a signal to the engine to maintain full/rated speed. At this engine speed the generator will run at its correct speed to maintain rated voltage with rated frequency.

When the switch is returned back to Compressor position, the engine will maintain the speed via pressure regulator valve and pressure transducer according to the air demand.

When connecting electrical equipment to any of the socket outlets, it is recommended that the appropriate MCB is in the *OFF* position before making the connection, switching the MCB to the *ON* position immediately prior to using the equipment.

PRIOR TO STARTING (GENERATOR) (WDG)

If the generator should become exposed or saturated with moisture/water deposits, it must be safely dried off before attempting to make any part or conductor electrically live. This should be done by wiping away excess water, then running the engine with no electrical loads connected, until the generator is completely dry.

Ensure all persons concerned are suitably competent with electrical installations.

Ensure that there is a safe working procedure which has been issued by supervisory personnel, and that it is understood by all persons concerned with the operation of the generator.

Ensure that the safety procedure to be applied is based on the appropriate national regulations.

Ensure that the safety procedure is followed at all times.

Ensure that suitable guidance codes are available to indicate safe working practices, and any hazards to avoid.

Before starting the engine and switching in the generator load, ensure that :-

- . The system has been inspected and earthed.
- . No persons are in a hazardous position.
- . Any warnings necessary have been suitably displayed (where applicable).

Ensure compressor / generator mode switch is set to compressor.

7/51

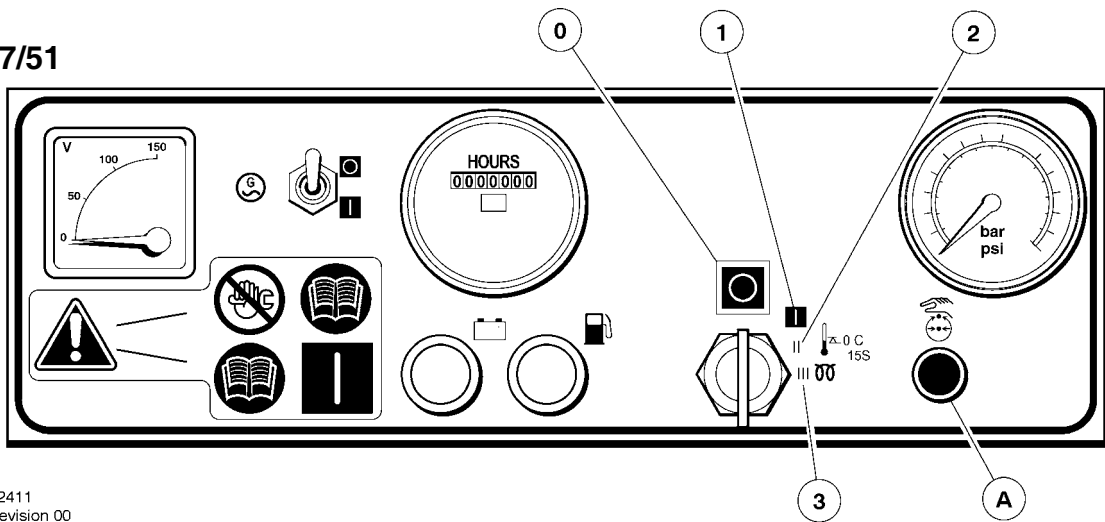

T2411
Revision 00
04/03

7/71, 12/56

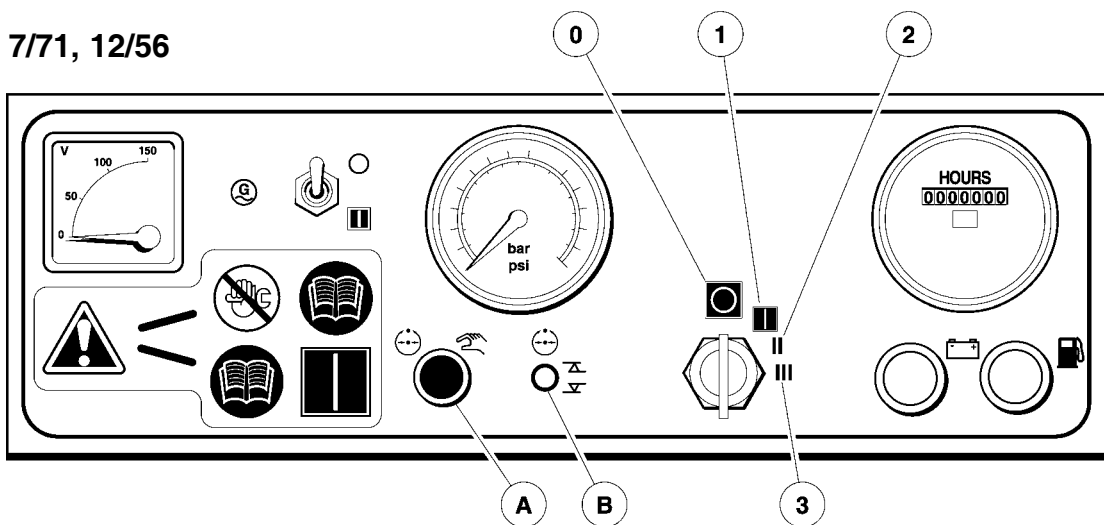

T1849B
Revision 00
01/03

STARTING THE MACHINE

WARNING: Under no circumstances should volatile liquids such as Ether be used for starting this machine.

CAUTION: Do not start or stop the machine with the compressor/generatormode switch in the **Generator** position. Engine starting/cranking is prevented in this mode – see also “Operating Instructions – SECU section”.

All normal starting functions are incorporated in the key operated switch.

Turn the key switch to position 2 and hold for 15 seconds max to allow the air inlet heater to reach working temperature.

- Turn the key switch to position 3 (engine start position).
- Release to position 2 when the engine starts.
- Release to position 1 when the alternator charge light is extinguished.

At temperatures below 0°C or if there is difficulty starting first time:

- Open the service valve fully, with no hose connected.
- Complete the starting sequence above.
- Close the service valve as soon as the engine runs freely.
- Do not allow the machine to run for long periods with the service valve open.
- Allow the engine to reach its operating temperature. Then press button A when fitted (Option on 7/51, standard on 7/71, 12/56).
- At this point in the operation of the machine it is safe to apply full load to the engine.

NOTE: Wear hearing protection at all times when the engine is started with the top open and air is flowing from the valve.

STOPPING THE MACHINE

- . Close the service valve.

- . Allow the machine to run unloaded for a short period of time to reduce the engine temperature.

- . Turn the start switch to the 0 (off) position.

NOTE: As soon as the engine stops, the automatic blowdown valve will relieve all pressure from the system.

If the automatic blowdown valve fails to operate, then pressure must be relieved from the system by means of the service valve(s).

CAUTION: Never allow the machine to stand idle with pressure in the system.

EMERGENCY STOPPING

In the event that the unit has to be stopped in an emergency, **TURN THE KEY SWITCH LOCATED ON THE INSTRUMENT PANEL TO THE 0 (OFF) POSITION.**

RE-STARTING AFTER AN EMERGENCY

If the machine has been switched off because of a machine malfunction, then identify and correct the fault before attempting to re-start.

If the machine has been switched off for reasons of safety, then ensure that the machine can be operated safely before re-starting.

Refer to the *PRIOR TO STARTING* and *STARTING THE UNIT* instructions earlier in this section before re-starting the machine.

MONITORING DURING OPERATION

Should any of the safety shut-down conditions occur, the unit will stop. These are:

- . Low engine oil pressure

- . High air discharge temperature

- . High engine oil temperature.

- . Alternator/drive belt failure circuit.

- . Low engine fuel level.

CAUTION: To ensure an adequate flow of oil to the compressor at low temperature, never allow the discharge pressure to fall below 3,5 bar.

DECOMMISSIONING

When the machine is to be permanently decommissioned or dismantled, it is important to ensure that all hazard risks are either eliminated or notified to the recipient of the machine. In particular: -

- . Do not destroy batteries or components containing asbestos without containing the materials safely.

- . Do not dispose of any pressure vessel that is not clearly marked with its relevant data plate information or rendered unusable by drilling, cutting etc.

- . Do not allow lubricants or coolants to be released into land surfaces or drains.

- . Do not dispose of a complete machine without documentation relating to instructions for its use.

MAINTENANCE

General

Ensure all electrical equipment is properly maintained and controlled.

Ensure all earth connections are secure and regularly maintained.

Earth leakage circuit breaker (ELCB)

The earth leakage circuit breaker must be mechanically tested daily by pushing the test button with the machine in its *no load* condition. The ELCB should trip to the *off* (down) position.

The earth leakage circuit breaker should also be tested every 3 months. A proprietary test meter should be used to induce live to earth preset flow at each socket outlet. This current flow will produce the required earth fault check. The test should be conducted in accordance with appropriate national standards.

Instruments and controls

A Voltmeter is provided to indicate the output voltage.

Miniature circuit breakers provide over-current protection. In the event of excess current the appropriate circuit breaker will trip to the *OFF* position

Note: The current trip rating is quoted at a nominal 40°C ambient temperature.

An earth leakage circuit breaker provides additional protection in the event of a leakage to earth in excess of 30 milliamperes on the connected appliance or in the connections to the generator.

For alternator maintenance refer to Mecc Alte operation and maintenance manual.

61 OPTIONS

FAULT FINDING

FAULT	CAUSE	REMEDY
No output.	<i>Load plugs not fitted into socket outlets correctly.</i>	Ensure that the load plugs are fitted correctly into the socket outlets.
No output.	<i>Loose connection.</i>	Remove end cover and terminal box lid and check for loose connections. Rectify the fault as necessary.
	<i>Faulty rectifier.</i>	Check the rectifier bridge which is located inside the rear housing.
	<i>Faulty capacitor.</i>	Check the capacitors.
	<i>The No load voltage is low but increases when a load is applied.</i>	Check the capacitors and associated wiring.
	<i>The No load voltage falls when a load is applied.</i>	Check the capacitors and associated wiring.
	<i>Loss of residual magnetic field</i>	Refer to Mecc Alte maintenance manual
No output.	<i>Output winding(s) damaged.</i>	Measure the voltage across the winding(s). Replace the generator if damaged.
	<i>Field winding damaged.</i>	Replace the generator.
Generator fails to provide maximum output.	<i>Engine is not running at full speed.</i>	Check the engine speed with a tachometer. Consult Ingersoll-Rand if the engine is found to be running slow (Refer to section 4 <i>General Information</i>).
	<i>Drive belt is not tensioned correctly.</i>	Re-tension the drive belt.
	<i>Drive pulley is loose on the drive shaft.</i>	Check the drive pulley and tighten as required.

FAULT	CAUSE	REMEDY
The output voltage collapses when a load is connected.	<i>Overload condition.</i>	Check and reset each circuit breaker. If the condition persists then investigate the cause and rectify the fault as necessary. (see also 'Circuit breaker trips')
	<i>Short circuit.</i>	Check for a short circuit and rectify the fault as necessary.
	<i>Incorrect wiring.</i>	Check the wiring and rectify the fault as necessary.
Circuit breaker trips.	<i>Overload condition.</i>	Check and reset each circuit breaker. If the condition persists then investigate the cause and rectify the fault as necessary. (see also 'Circuit breaker trips')
	<i>Short circuit.</i>	Check for a short circuit and rectify the fault as necessary.
	<i>Fault in appliance.</i>	Check the appliance and rectify the fault as necessary.
A circuit breaker fails to re-set whilst the machine running.	<i>Circuit breaker latching mechanism faulty.</i>	Repair or replace as necessary.
Refer to Engine Manufacturer's manual and Mecc Alte manufacturer's manual		

A.C. Electrical Power Schematic Diagram. 115V 1 – phase.

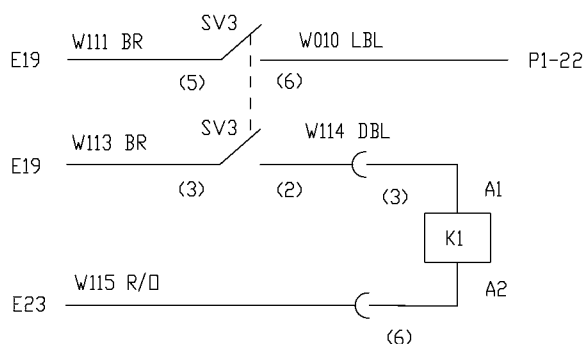
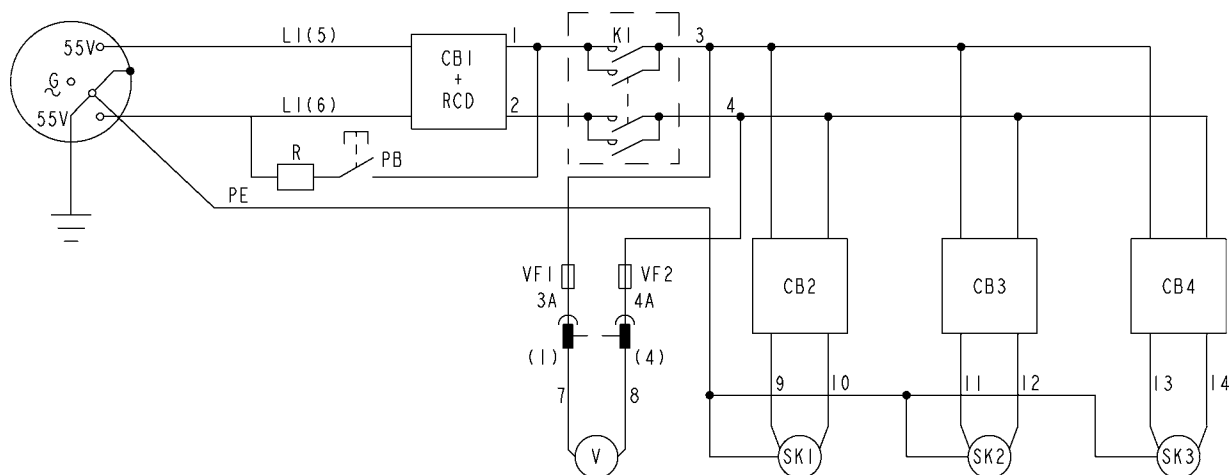

T2413_00
09/08

KEY

CB1	Circuit breaker 63A	R	Resistor
CB2	Circuit breaker 32A	SK1	Socket outlet 32A
CB3	Circuit breaker 16A	SK2	Socket outlet 16A
CB4	Circuit breaker 16A	SK3	Socket outlet 16A
G	Alternator	SV3	Switch, generator
K1	Contactor	V	Voltmeter
PB	Pushbutton	VF1	Fuse Voltmeter
PE	Protective earth conductor	VF2	Fuse Voltmeter

63 OPTIONS

A.C. Electrical Power Schematic Diagram. 230V 1 – phase.

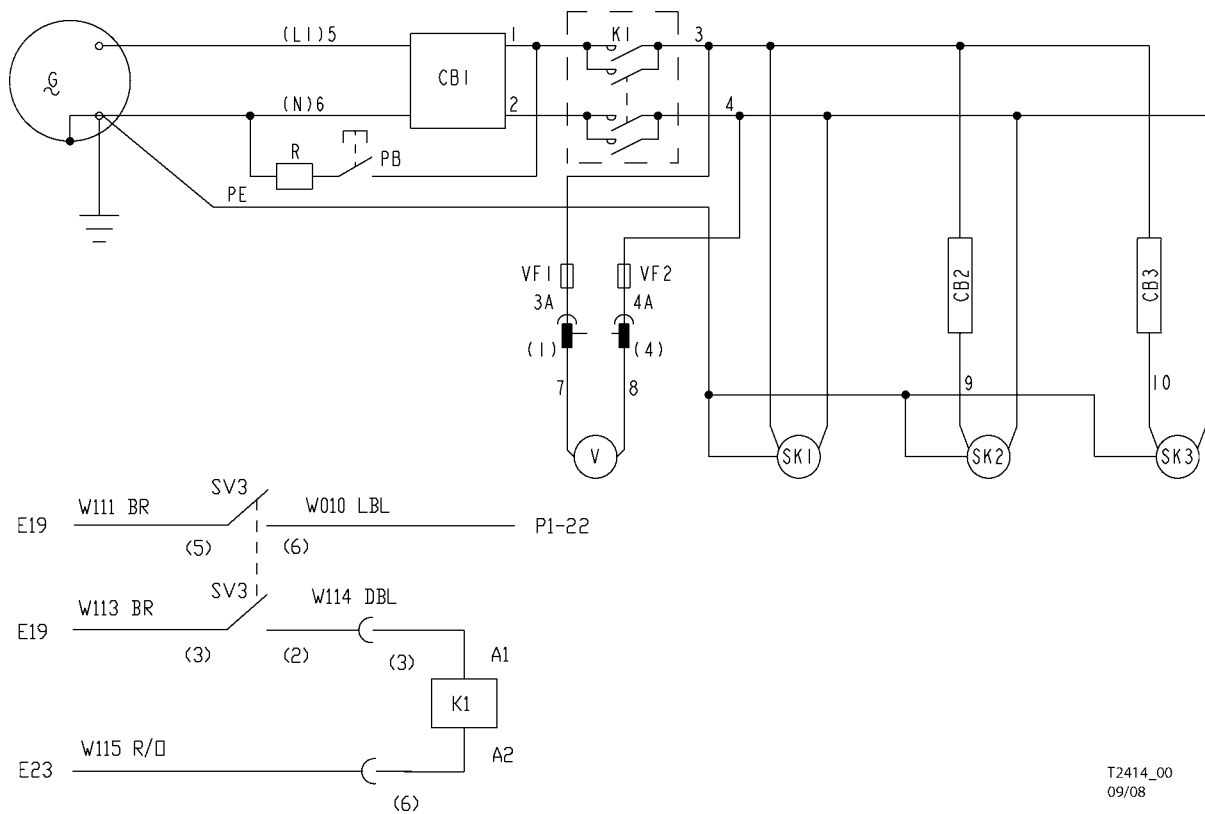

KEY

CB1	Circuit breaker 32A	R	Resistor
CB2	Circuit breaker 16A	SK1	Socket outlet 32A
CB3	Circuit breaker 16A	SK2	Socket outlet 16A
G	Alternator	SK3	Socket outlet 16A
K1	Contactor	SV3	Switch, generator
PB	Pushbutton	V	Voltmeter
PE	Protective earth conductor	VF1	Fuse Voltmeter
		VF2	Fuse Voltmeter

A.C. Electrical Power Schematic Diagram. 400/230V 3 – phase.

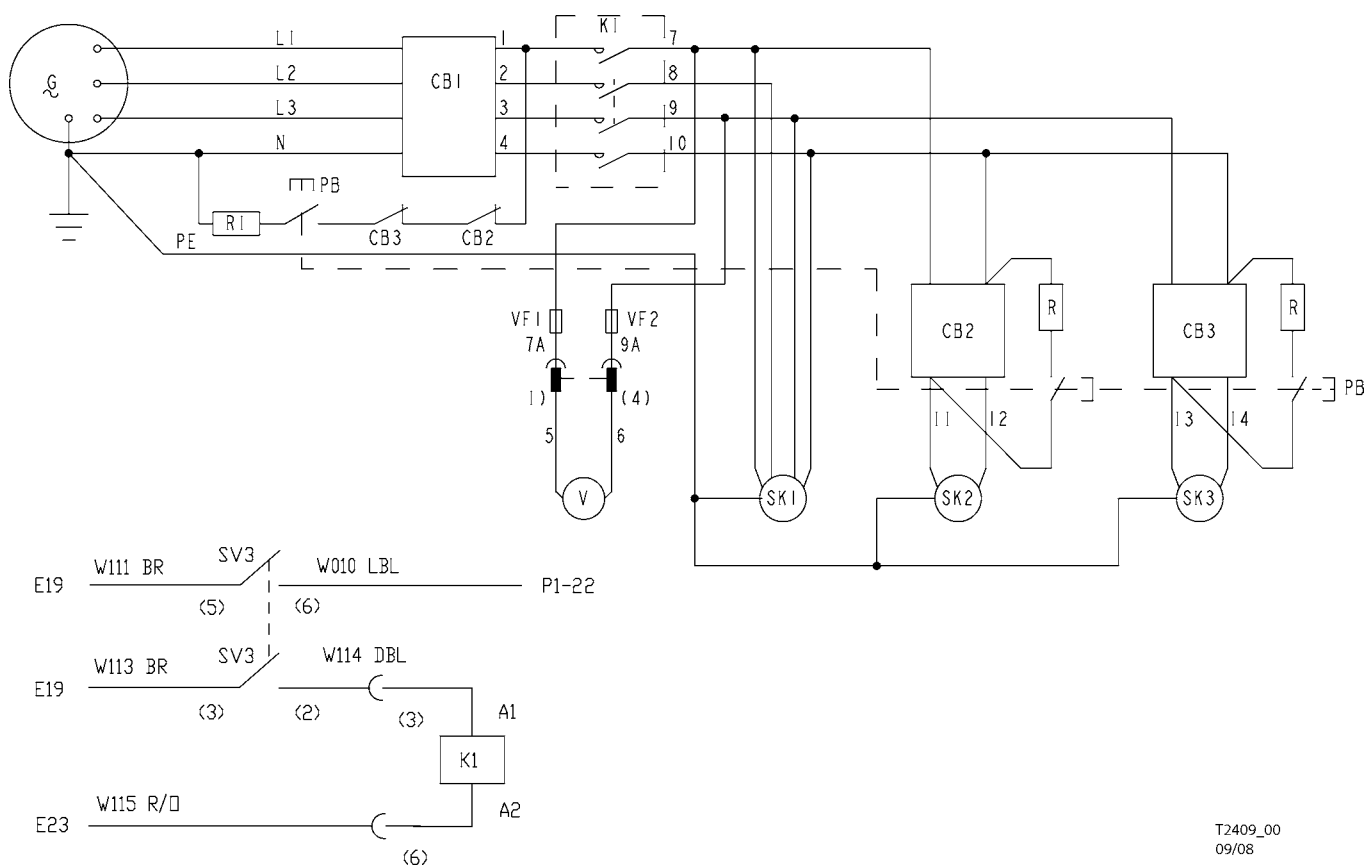

T2409_00
09/08

KEY

CB1	Circuit breaker 16A	R1	Resistor
CB2	Circuit breaker 10A	SK1	Socket outlet 16A
CB3	Circuit breaker 10A	SK2	Socket outlet 16A
G	Alternator	SK3	Socket outlet 16A
K1	Contactor	SV3	Switch, generator
PB	Pushbutton	V	Voltmeter
PE	Protective earth conductor	VF1	Fuse Voltmeter
R	Resistor	VF2	Fuse Voltmeter

4IRI8NE-2 / 4IRI8TE ENGINES

CONTENTS

- 66 **FOREWORD**
- 67 **EXTERNAL VIEW :**
 4IRI8NE-2 / 4IRI8TE
- 68 **GENERAL INFORMATION:**
 4IRI8NE-2 / 4IRI8TE
- Main data and specifications
- Engine identification
- Portable Power engine after sales support
- EMISSION CONTROL LABEL**
- 70 **FUEL, LUBRICANT, AND COOLANT**
- Fuel
- Lubricant
- Coolant
- 72 **OPERATION**
- Check before operation
- Check and operation after start- up
- Operation and care of a new engine
- 75 **PERIODICAL INSPECTION**
 AND MAINTENANCE
- Lubricating system
- Cooling system
- Fuel system
- Air intake system
- Routine maintenance
- 79 **TROUBLESHOOTING**

ENGINE – General Information

The Portable Power industrial diesel engines are a product of long years of experience, advanced technology, and up-to date production facilities. Portable Power takes great pride in the superior durability and operating economy of these engines.

In order to get the fullest use and benefit from your engine, it is important that you operate and maintain it correctly. This Manual is designed to help you do this.

Please read this Manual carefully and follow its operating and maintenance recommendations. This will ensure many years of trouble-free and economical engine operation.

Should your engine require servicing, please contact your nearest Portable Power branch or distributor.

All information, illustrations, and specifications contained in this Manual are based on the latest product information available at the time of publication.

Portable Power reserves the right to make changes in this Manual at any time without prior notice.

DIESEL ENGINE Engine External View – Model

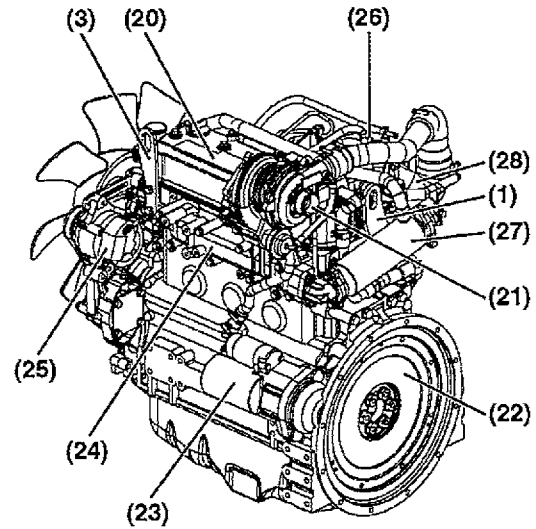
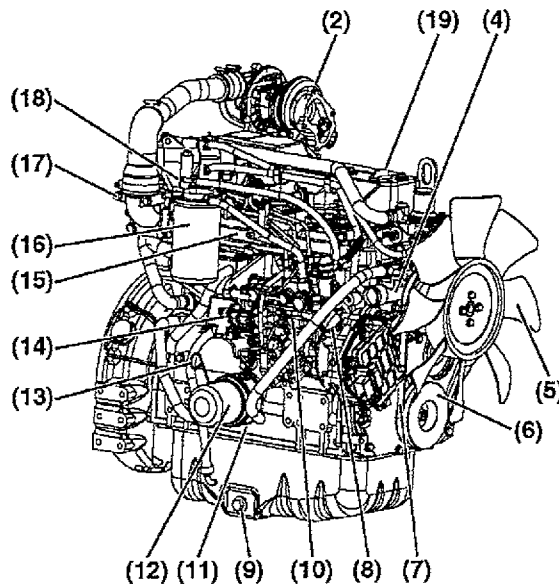

1. Lifting eye (Flywheel end)
2. Turbocharger
3. Lifting eye (Engine cooling fan end)
4. Engine coolant pump
5. Cooling fan
6. Crank shaft V-pulley
7. V-belt
8. Filler port (engine oil)
9. Drain plug (engine oil)
10. Fuel injection pump
11. Engine oil cooler
12. Engine oil filter
13. Dipstick (engine oil)
14. Eco-governor

15. Intake manifold
16. Fuel filter
17. Fuel oil inlet
18. Fuel return to fuel tank
19. Filler port (Engine oil)
20. Rocker arm cover
21. Air intake port (From air cleaner)
22. Flywheel
23. Starter motor
24. Exhaust manifold
25. Alternator
26. EGR valve
27. EGR cooler
28. EGR pipe

EPA CERTIFIED ENGINE DATA and SPECIFICATIONS

Model: 4IRI8NE-2 / 4IRI8TE

Engine model name	4IRI8NE-2 / 4IRI8TE	
Engine type	Vertical inline water cooled diesel engine	
Combustion type	Direct injection	
Aspiration	Natural / Turbocharged	
No. of cylinders – bore x stroke. mm	4–98x110	
Engine displacement L	3.319	
Compression ratio	18.5:1 / 18.1:1	
Firing order	1 –3 – 4 – 2	
Exhaust emission control system	Fuel injection nozzles, fuel injector pump	
Governor	Electronic	
Specified fuel	Diesel fuel (ISO 8217 DMX, BS2869 A1/A2) No. 2–3, No. 1–D, ASTM D975–94	
Starter (V–kW)	12–2.3	
Alternator (V–A)	12–40	
Specified engine oil (API grade) (SAE grade)	CI–4+ (15W40)	
Coolant volume (Engine only) L	4.2	
Engine dry weight kg	235 / 245	
Engine dimensions	Overall length mm	719
	Overall width mm	508
	Overall height mm	717
Nozzle injection pressure MPa	21.6	

ENGINE IDENTIFICATION

Serial No Location

The engine serial number is stamped on engine name plate on top of rocker cover.

Confirmation of Engine Number

It is advisable to quote the engine serial number together with the machine serial number, as it is required when you contact the Portable Power branch or distributor for repair, service or parts ordering.

CAUTION: Conduct confirmation of engine serial number with the engine stopped. To avoid being injured, do not check it, while the engine is still hot.

ENGINE AFTER SERVICE

Contact your Portable Power dealer for periodical inspection and maintenance.

Portable Power parts are identical with those used in the engine production, and accordingly, they are warranted by Portable Power.

Genuine Ingersoll–Rand parts are supplied by your Portable Power branch or distributor.

Please ensure that only genuine Ingersoll–Rand parts, lubricants and fluids are used for service and/or repair.

ENGINE LABEL (FOR EPA)

Emission control label is attached on the "top of rocker arm cover."

The location of emission control label attached on the engine may vary depending on the engine specification

The following is the sample of a label required for engine emission control information, along with location.

IMPORTANT ENGINE INFORMATION	
THIS ENGINE CONFORMS TO <input type="checkbox"/>	
THIS ENGINE IS CERTIFIED TO OPERATE ON	
ENGINE FAMILY: <input type="checkbox"/>	DISPLACEMENT: <input type="checkbox"/> LITERS
ENGINE MODEL: <input type="checkbox"/>	EMISSION CONTROL SYSTEM: EM
FUEL RATE: <input type="checkbox"/> INCH ³ /STROKE @ <input type="checkbox"/> MM/ <input type="checkbox"/> RPM	
REFER TO OWNER'S MANUAL FOR MAINTENANCE SPECIFICATIONS AND ADJUSTMENTS.	

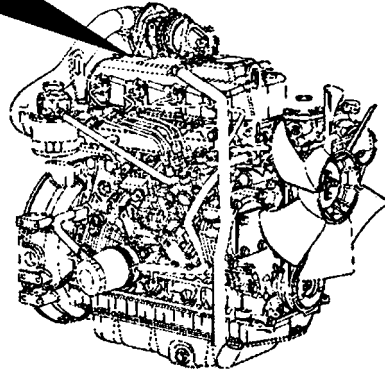

FUEL

Fuel Selection

The following properties are required of the diesel fuel.

Must have high cetane value., (45 or greater)

The sulfur content must not exceed 0.5% by volume. A higher sulfur content fuel may cause sulfuric acid corrosion in the cylinders of the engines.

NEVER mix kerosene, used engine oil, or residual fuels with the diesel fuel.

Water and sediment in the fuel should not exceed 0.05% by volume.

Keep the fuel tank and fuel-handling equipment clean at all times.

Poor quality fuel can reduce engine performance and/or cause engine damage.

Fuel additives are not recommended. Some fuel additives may cause poor engine performance. Consult your Portable Power representative for more information.

Ash content not to exceed 0.01% by volume.

Carbon residue content not to exceed 0.35% by volume. Less than 0.1% is preferred.

Total aromatics content should not exceed 35% by volume. less than 30% is preferred.

PAH (polycyclic aromatic hydrocarbons) content should be below 10% by volume.

Metal content of Na, Mg, Si, and Al should be equal to or lower than 1 mass ppm. (Test analysis method JPI-5S-44-95).

Lubricity: Wear mark of WS1.4 should be Max. 01018 in (460 um) at HFRR test.

Diesel fuel should comply with the specifications listed in the table below. The table lists several worldwide specifications for diesel fuels.

Diesel Fuel Specification	Location
No. 2-D, No. 1-D, ASTM D975-94	USA
EN590:96	European Union
ISO 8217 DMX	International
BS (BRITISH STANDARD) BS2869-A1 or A2	United Kingdom
JIS K2204 Grade No. 2	Japan
KSM-2610	Korea
GB252	China

FUEL REQUIREMENTS

Notice: the fuel injection pump, injector or other parts of the fuel system and engine can be damaged if you use any fuel or fuel additive other than those specifically recommended by Portable Power.

NOTE: If any fuel other than the one specified is used, engine operation will be impaired. Engine failure or malfunction resulting from use of such improper fuel will not be warranted by Portable Power.

To help avoid fuel system or engine damage, please read the following:

Do not use diesel fuel which has been contaminated with engine oil. Besides causing engine damage, such fuel can also affect emission control. Before using any diesel fuel, check with the fuel supplier to see if the fuel has been mixed with engine oil.

Your engine is designed to use either Number 1-D or Number 2-D diesel fuel. However, for better fuel economy, use Number 2-D diesel fuel whenever possible. At temperatures less than -7°C, (20°F), Number 2-D fuel may pose operating problems (see "Cold Weather Operation" which follows). At colder temperatures, use Number 1-D fuel (if available) or use a "winterized" Number 2-D (a blend of Number 1-D and Number 2-D). This blended fuel is usually called Number 2-D also, but can be used in colder temperatures than Number 2-D fuel which has not been "winterized."

Check with the fuel supplier to be sure you get the properly blended fuel.

NOTICE: Do not use home heating oil or gasoline in your diesel engine; either may cause engine damage.

Handling of the Fuel.

Any fuel containing dust particles or water might cause engine failure.

Therefore, the following must be observed.

Take care to protect the fuel from ingress of dust particles or water when filling the fuel tank.

If refueling is done from an oil drum directly, ensure that it has been kept stationary to allow any dust, sediment or water to settle at the bottom. Do not draw fuel direct from the bottom of the drum to prevent pickup of any settled foreign material.

Always fully fill the fuel tank. Drain the sedimented particles in the fuel tank frequently.

Water in Fuel

During refueling, it is possible for water (and other contaminants) to be pumped into your fuel tank along with the diesel fuel. This can happen if a fuel provider does not regularly inspect and clean its fuel tanks, or receives contaminated fuel from its supplier(s). To protect your engine from contaminated fuel, there is a fuel filter system on the engine which allows you to drain excess water.

CAUTION: The water/diesel fuel mixture is flammable, and could be hot. To avoid personal injury and/or property damage, do not touch the fuel coming from the drain valve, and do not expose the fuel to open flames or sparks.

Be sure you do not overfill the fuel tank. Heat (such as from the engine) can cause the fuel to expand. If the tank is too full, fuel could be forced out. This could lead to a fire and the risk of personal injury and/or equipment damage.

Biocides

In warm or humid weather, fungus and/or bacteria may form in diesel fuel if there is water in the fuel.

NOTICE: Fungus or bacteria can cause fuel system damage by plugging the fuel lines, fuel filters or injector. They can also cause fuel system corrosion.

If fungus or bacteria has caused fuel system problems, you should have your authorized dealer correct these problems. Then, use a diesel fuel biocide to sterilize the fuel system (follow the biocide manufacturer's instructions). Biocides are available from your dealer, service stations, parts stores and other automotive places. See your authorized dealer for advice on using biocides in your area and for recommendations on which biocides you should use.

Smoke Suppressants

The use of a smoke suppressant additive is not allowed because of the greater possibility of stuck rings and valve failure, resulting from excessive ash deposits.

71 FUEL, LUBRICANTS, AND COOLANT

LUBRICANT.

The quality of engine oil can affect engine performance, startability and engine life.

Use of unsuitable engine oil will result in piston ring, piston and cylinder seizure and accelerate surface wear causing increased oil consumption, lowered output and, finally engine failure. To avoid this, use the specified engine oil.

1) Engine Oil Selection

Pro Tec™

2) Oil Viscosity

Engine oil viscosity affects engine startability, performance, oil consumption, wear and the potential for seizure, etc. Always ensure that lubricants with the correct viscosity for the operating temperature are used. Refer to fig 12.

NOTE

Using a mixture of different brands or quality of oils will adversely affect the original oil quality; therefore, never mix different brand or different type oils.

Do not use API, CA, CB grade and reconstituted engine oil

Engine damage due to improper maintenance, or using oil of the improper quality and/or viscosity, is not covered by the warranty.

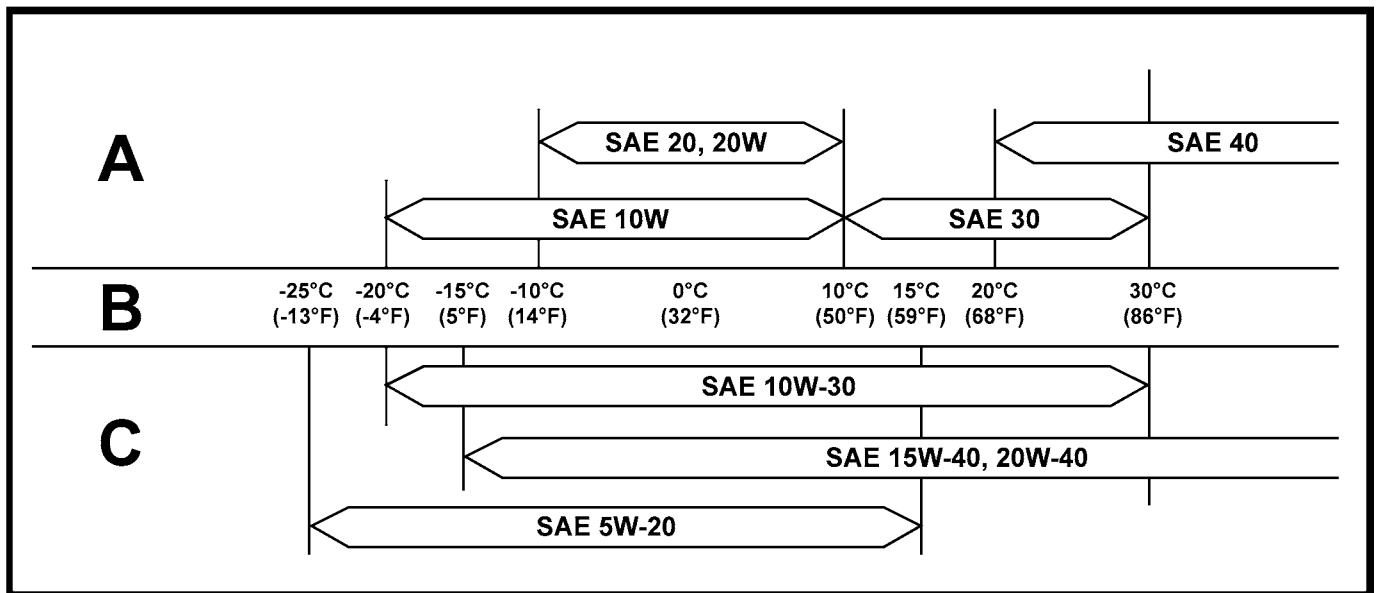

Fig. 12

A. (Single – grade)

B. Ambient Temperature

C. (Multi – grade)

COOLANT

All Portable Power compressor engines are factory filled with a 50/50 Ethylene glycol base antifreeze/water mix. which provides protection to -33°C (-27°F)

IMPORTANT:

- Be sure to add Long Life Coolant Antifreeze (LLC) to soft water. In cold season, the LLC is especially important. Without LLC, cooling performance will decrease due to scale and rust in the cooling water line. Without LLC, cooling water will freeze and expand to break the cooling line.
- Be sure to use the mixing ratios specified by the LLC manufacturer for your temperature range.
- Do not mix different types (brand) of LLC, chemical reactions may make the LLC useless and engine trouble could result
- Replace the cooling water every once a year

CAUTION:

When handling Long Life Coolant Antifreeze, wear protective rubber gloves not to contact with it. If contact with the eyes or skin should occur, wash with clean water

ENGINE OPERATION

Engine Exhaust Gas Caution (Carbon Monoxide)

CAUTION

Do not breathe exhaust gas because it contains carbon monoxide, which by itself has no color or odor. Carbon monoxide is a dangerous gas. It can cause unconsciousness and can be lethal.

Do not run the engine in confined areas (such as garages or next to a building). Keep the exhaust tailpipe area clear of snow and other material to help reduce the buildup of exhaust gases under the equipment. This is particularly important when parked in blizzard conditions.

CHECK BEFORE OPERATION

CAUTION: For safety reasons, conduct the inspection with the engine stopped.

Engine Oil Level.

Place the engine or the machine on a level surface

Remove the dipstick, wipe it with a cloth. Insert it fully and take it out gently again.

Check the oil level against the marks on the dipstick. The oil level must be between the upper level mark and the lower level mark as illustrated.

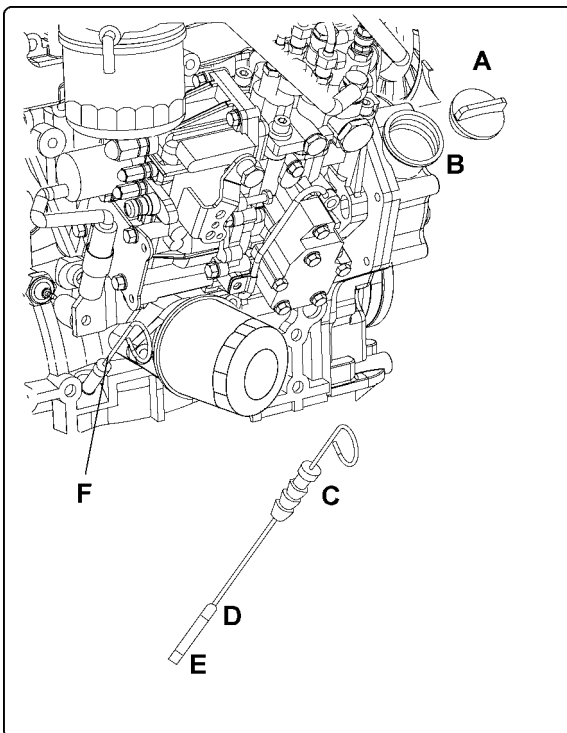

- A. Filler cap
- B. Filler port (engine oil)
- C. Dipstick
- D. Upper limit
- E. Lower limit
- F. Dipstick

Remove filler cap (yellow coloured) on the rocker arm cover side of engine.

Fill with engine oil up to the upper limit on the dipstick.

Manually tighten the filler cap.

Do not use a tool such as pliers to tighten it.

Engine oil pan capacity (oil pan) (L) – 10.2 (10.8 quarts).

A certain period of time is required before the engine oil completely flows down from the oil filler to the crankcase. Wait at least ten minutes before checking the oil level.

NOTE: Take care to avoid engine oil being splashed on the fan drive belt because it causes belt slippage or slackness.

CAUTION: When adding oil, take care not to spill it. If you spill oil on the engine or equipment, wipe it properly, to prevent the risk of fire and personal injury and/or equipment damage.

Fan Belt Check

Check the fan belt for tension and abnormalities.

When the belt is depressed 7 – 10 mm with the thumb (about 100N [10 kg] pressure) midway between the fan pulley and alternator pulley, the belt tension is correct.

If the belt tension is too high, it will result in alternator failure.

A loose belt will cause belt slippage which may result in a damaged belt, abnormal noise, poor battery charging and engine overheating.

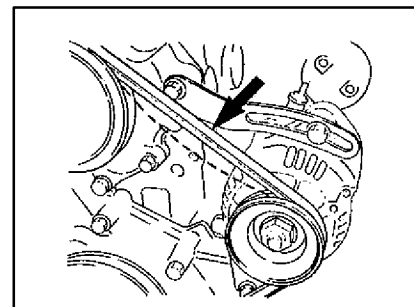

Fig. 16

Coolant Level Check

The coolant level must be between “MAX COLD” and “MIN” marks on the reserve tank depending on the temperature of the engine. Check and ensure that the level is correct.

CAUTION: When removing the radiator filler cap, while the engine is still hot, cover the cap with cloth, then turn it slowly to gradually release the internal steam pressure. this will prevent anyone from being scalded by hot steam spurting out from the filler neck.

Add coolant mixed to the correct ratio: 50/50 ethylene glycol/water.

Radiator Cap Condition

After the replenishment of the coolant, install the radiator filler cap. Make sure the cap is securely installed.

Battery Cable Connection

Check the battery cable connections for looseness or corrosion. A loosened cable connection will result in hard engine starting or insufficient battery charge. The battery cables must be tightened securely. Never reverse “+” and “-” terminals when reconnecting cables after disconnection. Even a short period of reverse connection will damage the electrical parts.

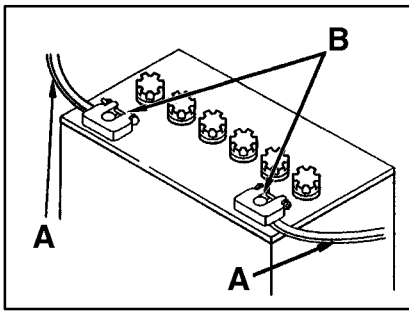

Fig. 17

- A Battery cable
- B Connections

Battery Electrolyte level

The amount of electrolyte in the batteries will be reduced after repeated discharge and recharge. Check the electrolyte level in the batteries, replenish with a commercially available electrolyte such as distilled water, if necessary. The battery electrolyte level checking procedure will vary with battery type. **NOTICE:** Do not replenish with dilute sulfuric acid in the daily service.

CAUTION:

When inspecting the batteries, be sure to stop the engine first.

As dilute sulphuric acid is used as electrolyte, be careful not to contaminate your eyes, hands, clothes, and metals with the electrolyte. If it gets in your eye, wash with a large amount of water at once, then seek medical advice.

As highly flammable hydrogen gas is released from the batteries, do not create a spark or allow any naked flame near the batteries.

When handling such metallic articles as tools near the batteries, be sure not to contact the "+" terminal because the compressor body is "-" and a dangerous short circuit might result.

When disconnecting the terminals, start with "-" terminal. When connecting them, connect the "-" terminal last.

Fuel level

Check the remaining fuel oil level in the fuel tank and re-fuel if necessary.

CHECKS AND OPERATION AFTER START-UP

Check after the Engine Start-up

Check the following items in the engine warming-up operation.

Engine noise and exhaust smoke color -

Listen to the engine and, if any abnormal noise is heard, check to determine the cause.

Check the fuel combustion condition by observing the exhaust smoke color. The exhaust smoke color after engine warm-up and at no-load condition should be colorless or light blue.

Black or white smoke indicates incorrect combustion.

Note: After start-up from cold the engine might be noisier and the exhaust smoke color darker than when it has warmed up. However this condition will disappear after warm up.

Leakage in the systems -

Check the following items:

Lubrication oil leakage -

Check the engine for oil leaks, paying particular attention to oil filter and oil pipe joints.

Fuel leakage -

Check the fuel injection pump, fuel lines and fuel filter for leakage.

Coolant leakage -

Check the radiator and water pump hose connections and the water drain cock on the cylinder block for leakage.

Exhaust smoke or gas leakage.

Checking coolant level

The coolant level could drop because any mixed air is expelled in about 5 minutes after the engine started.

Stop the engine, remove radiator cap, and add coolant.

CAUTION: Hot steam can rush out and you could get burnt if the radiator cap is removed when the engine is hot. Cover the radiator cap with a thick cloth and loosen the cap slowly to reduce the pressure, then remove the cap.

OPERATION AND CARE OF A NEW ENGINE

Your Portable Power engine is carefully tested and adjusted in the factory, however, further run-in is necessary. Avoid any harsh engine operation within the initial 100 operating hours.

Do not operate the unit at full load until the engine is warmed-up.

Do not allow the engine to run unloaded for extended periods so as to minimise the risk of cylinder bore glazing.

During operation, pay attention to the following points if the engine shows any sign of abnormalities.

(1) Engine Oil Pressure – The engine oil pressure is monitored by a switch that will stop the engine if the pressure falls below a pre-set value.

(2) Coolant Temperature – The engine performance will be adversely affected if engine coolant temperature is too hot or too cold. The normal coolant temperature is 75 to 85°C (167 to 185°F).

Overheating

CAUTION:

If you see or hear escaping steam or have other reason to suspect there is a serious overheat condition, stop the engine immediately.

If the Engine Coolant Temperature gage (where fitted) shows an overheat condition, or you have reason to suspect the engine may be overheating, take the following steps:

- Close the service valve to reduce the load.
- Let the engine run at normal idle speed for two or three minutes. If the engine coolant temperature does not start to drop, turn off the engine and proceed as follows:

CAUTION: To help avoid being burned –

- Do not open the canopy or door if you see or hear steam or engine coolant escaping. Wait until no steam or engine coolant can be seen or heard before opening the engine canopy or door.
- Do not remove the radiator filler cap if the engine coolant in the reserve tank is boiling. Also do not remove the radiator filler cap while the engine and radiator are still hot. Scalding fluid and steam can be blown out under pressure if either cap is taken off too soon.

If no steam or engine coolant can be seen or heard, open the canopy or door. If the engine coolant is boiling, wait until it stops before proceeding. The engine coolant level should be between the "MAX COLD" and "MIN" marks on the reserve tank.

Make sure the fan belt is not broken, or off the pulley, and that the fan turns when the engine is started. If the engine coolant level in the reserve tank is low, look for leaks at the radiator hoses and connections, radiator, and water pump. If you find major leaks, do not run the engine until these problems have been corrected. If you do not find a leak or other problem, **WAIT UNTIL THE ENGINE HAS COOLED DOWN** then carefully add engine coolant to the reserve tank.

(Engine coolant is a mixture of ethylene glycol antifreeze and water. See "Engine Care in cold season" for the proper antifreeze and mixture.)

CAUTION: To avoid being burned, do not spill antifreeze or engine coolant on the exhaust system or hot engine parts. Under some conditions the ethylene glycol in engine coolant is combustible.

If the engine coolant level in the reserve tank is at the correct level but there is still an indication of an overheat condition and no cause was found, please consult your local branch or dealer.

Overcooling

Operating the engine at low coolant temperature will not only increase the oil and fuel consumption but also will lead to premature parts wear which may result in engine failure. Ensure that the engine reaches normal operating temperature 75 to 85°C (167 to 185°F) within ten minutes of starting.

(3) Hourmeter

This meter indicates the machine operation hours. Make sure that the meter is always working during engine operation. Periodical machine maintenance is scheduled on the operation hours indicated on the hourmeter.

(4) Liquid and Exhaust Smoke Leakage

Make regular checks for lubricant, fuel, coolant and exhaust smoke leakage.

(5) Abnormal Engine Noise

In the event of any abnormal engine noise, please consult your local branch or dealer.

(6) State of the Exhaust Smoke

Check for any abnormal exhaust smoke color.

ENGINE STOPPING

(1) Close service valves.

(2) Before stopping the engine, cool down the engine by operating it at reduced load about three minutes. In this period, check the engine noise for abnormalities.

LONG TERM STORAGE

If the equipment is to be out of operation for an extended period, it should be started at least once per week and run on load for about 15 minutes after it has reached normal operating temperature.

If this is not possible,

- Do not drain the cooling water
- Clean dust or oil from the engine extension
- Either fill completely or drain the fuel tank
- Grease accelerator joints and electrical connections
- Disconnect the negative battery terminal

ENGINE MAINTENANCE

Inspection after initial 50 hours operation

(1) Replacing the engine oil and engine oil filter (1st time)

When the engine oil is still hot, be careful with a splash of engine oil which may cause burns. Cool the engine to replace engine oil until the engine oil becomes warm. It is most effective to drain the engine oil while the engine is still warm.

In early period of use, the engine oil gets dirty rapidly because of the initial wear of internal parts. Replace the engine oil earlier.

Engine oil filter should also, be replaced when the engine oil is replaced.

Engine oil and engine oil filter replacing procedures are as follows.

Remove the oil filler cap to drain easily while draining the engine oil.

- 1) Prepare a waste oil container collecting waste oil.
- 2) Loosen the drain plug using a wrench (customer procured) to drain the engine oil.
- 3) Securely tighten the drain plug after draining the engine oil.
- 4) Turn the engine oil filter counter-clockwise using a filter wrench (customer procured) to remove it.
- 5) Clean the engine oil filter mounting face.
- 6) Moisten the new engine oil filter gasket with the engine oil and install the new engine oil filter manually turning it clockwise until it comes into contact with the mounting surface, and tighten it further to 3/4 of a turn with the filter wrench.

Tightening torque: 19.6~23.5N•m (2.0~2.4kgf•m)

Applicable engine oil filter Part No.	CCN 22226351
---------------------------------------	--------------

7) Fill with the new engine oil until it reaches the specified level as explained in OPERATION section.

8) Warm up the engine by running for 5 minutes while checking any oil leakage.

9) Stop the engine after warming up and leave it stopping for about 10 minutes to recheck the engine oil level with dipstick and replenish the engine oil. If any oil is spilled, wipe it away with a clean cloth.

10) Resume engine oil and filter changes at 250 our intervals (with non IR fluids) or 500 hour intervals with Ingersoll Rand Protec™ engine fluid and filters.

NOTE: The use of genuine Ingersoll Rand oil and filters will qualify for extended warranty coverage. Refer to Warranty Section of the manual.

Ingersoll Rand Protec™ Engine Fluid Part No. 54480918 (1 gallon).

IMPORTANT:

Do not overfill the oil pan with engine oil. Be sure to keep the specified level between upper and lower limit on the dipstick.

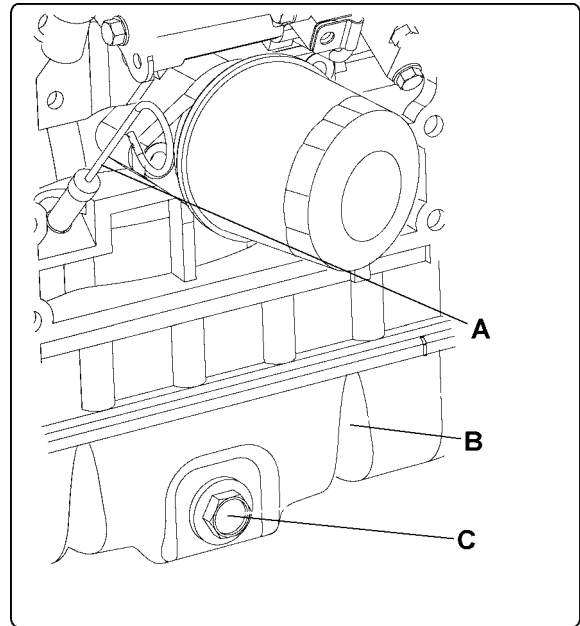

The location depends on the engine installed on the machine unit

- A. Dipstick
- B. Oil pan
- C. Drain plug

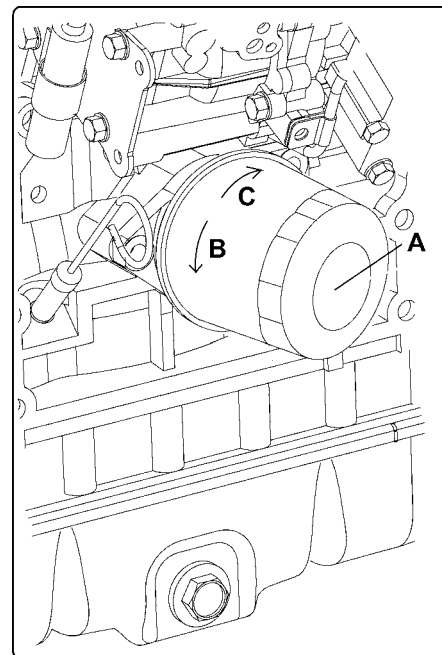

- A. Engine oil filter
- B. Loosen
- C. Tighten

(2) Draining Water from Fuel Filter/separator.

The fuel filter/separator is provided to allow water to be drained from the fuel system. Water is heavier than fuel so any water contained in the system will collect in the bottom of the bowl.

The clear bowl 'D' should be checked on a daily basis and if water is present, it should be drained from the separator.

Place a suitable container under the separator to prevent any spillage inside the machine.

Slacken the drain valve 'E' until water drains from the vent tube.

When all the water has been evacuated, tighten the drain valve 'E' and follow the "fuel system air bleeding" procedure below.

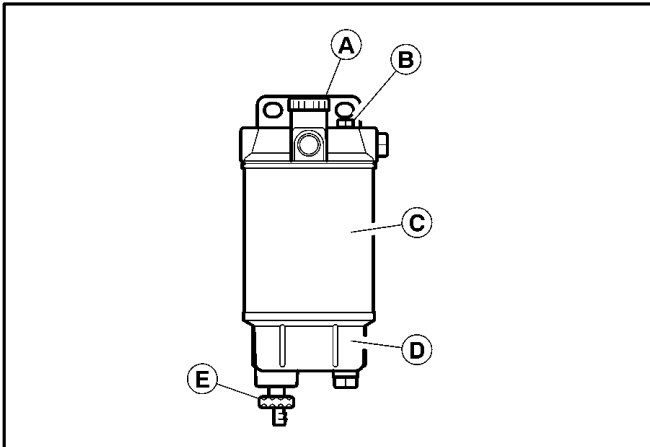

(3) Fuel System Air Bleeding

The entry of air into the fuel system will cause difficult engine starting or engine malfunction.

When carrying out service procedures such as emptying the fuel tank, draining the filter/separator, and changing the fuel filter element be sure to bleed air from the fuel system.

To activate the "automatic air-bleeding system", turn the key switch to the "ON" position and energize the electromagnetic pump" to bleed the air.

Air bleeding method:

When the "starter switch" is set to the "ON" position to activate the electromagnetic pump, fuel is forced to the fuel valve of each injection pump and then to the leak-off pipe of each injector nozzle, so that any air in the fuel system bleeds off automatically to the fuel tank.

NOTE:
 Although the fuel system can bleed air automatically when the key switch is in the "ON" position, air can also be manually bled by use of the primer pump facility in the filter/separator assembly. By unscrewing the plastic primer pump head 'A' and stroking it up and down, any air bubbles in the system will be purged back to the fuel tank. When this has been completed, the pump head must be screwed back into the filter/separator assembly.

Start the engine and visually check the fuel system for leaks.

(4) Replacing fuel filter

Replace the fuel filter at specified intervals before it is clogged with dust to adversely affect the fuel flow. Also, replace the fuel filter after the engine has fully been cooled.

1) Remove the fuel filter using a filter wrench (customer procured). When removing the fuel filter, hold the bottom of the fuel filter with a piece of rag to prevent the fuel oil from dropping. If you spill fuel, wipe such spillage carefully.

2) Clean the filter mounting surface and slightly apply fuel oil to the gasket of the new fuel filter.

3) Install the: new fuel filter manually turning until it comes into contact with the mounting surface, and tighten it further to 1/2 a turn, using a filter wrench. Tightening torque: 11.8~15.6N•m(1.2~1.6kgf•m).

Applicable fuel filter Part No.	CPN 16539462
---------------------------------	--------------

4) Bleed the fuel system. Refer to Inspection at 50 hours.

IMPORTANT:
 Be sure to use genuine IR part (super fine mesh filter). Otherwise, it results in engine damage, uneven engine performance and shorter engine life.

(4) Changing oil/water separator element.

NOTE:
 The cartridge and bowl contain fuel. Take care not to spill it during disassembly and reassembly.

The fuel filter/separator also provides primary filtration and the element 'C' should be changed every 500 operating hours or 6 months, whichever comes first.

Change procedure:

Unscrew the element 'C' from the head taking care not to spill fuel inside the machine. Drain any fuel within into a suitable container, then unscrew the clear bowl 'D' from the element.

Discard the old element into a suitable container.

Remove the old 'O' ring from the bowl 'D' and install the new one supplied with the element. Apply a light coat of clean engine oil to the 'O' ring and screw the bowl 'D' onto the new element 'C'.

Using a clean cloth, wipe the sealing face of the filter/separator head to ensure correct seating of the sealing ring.

Fill the element/bowl assembly with clean fuel oil then apply a light coat of clean engine oil to the new element seal ring.

Screw the new element onto the head firmly by hand.

Follow the "fuel system air bleeding" procedure.

Inspection every 1000 hours operation**(1) Replacing cooling water**

Cooling water contaminated with rust or water scale reduces the cooling effect. Even when antifreeze agent (LLC) is mixed, the cooling water gets contaminated due to deteriorated ingredients. Replace the cooling water at least Once a year.

- 1) Remove the header tank cap.
- 2) Remove the bottom radiator hose of the radiator and drain the cooling water.
- 3) After draining the cooling water, reconnect the hose.
- 4) Fill radiator and engine with cooling water via the header tank.

CAUTION:

Wait until the temperature goes down before draining the Cooling water. Otherwise, hot water may splash to cause scalding.

(2) Adjusting intake / exhaust valve clearance

As this adjustment requires specialized knowledge and skill, consult your Portable Power dealer. The adjustment is necessary to maintain the correct timing for the opening and closing of valves. Neglecting the adjustment will cause the engine to run noisily and result in poor engine performance and other damage.

Inspection every 1500 hours operation**(1) Inspect, Clean and Test Fuel Injectors**

As the adjustment requires specialized knowledge and skill, consult your Portable Power dealer. This adjustment is needed to obtain the optimum injection pattern for full engine performance.

(2) Inspect Turbocharger (Blower Wash as Necessary)

Turbo charger service is required by the EPA/ARB every 1500 hours. Your authorized Portable Power dealer or distributor will inspect and blower wash the unit if necessary.

(3) Inspect, Clean and Test EGR Valve

The EGR valve is a key component for cleaning exhaust gas.

To prevent the valve from deteriorating in exhaust gas recirculation performance due to carbon accumulation, inspect, clean and test the valve at least every 1500 hours. Consult your local Portable Power dealer for this service.

(4) Inspect and Clean EGR Lead Valve

The EGR lead valve is located in the passage of recirculated gas.

To prevent carbon accumulation in or clogging of the lead valve, inspect and clean the lead valve at regular intervals. Consult your local Portable Power dealer for this service.

(5) Clean EGR Cooler

The EGR cooler is apt to be contaminated with rust and scale that deteriorate the cooling performance. Carbon accumulation in the exhaust gas passage of the cooler hinders circulation of exhaust gas, resulting in deterioration in exhaust gas cleanup performance.

To prevent such a problem, clean the cooler at least every 1500 hours. Consult your local Portable Power dealer for this service.

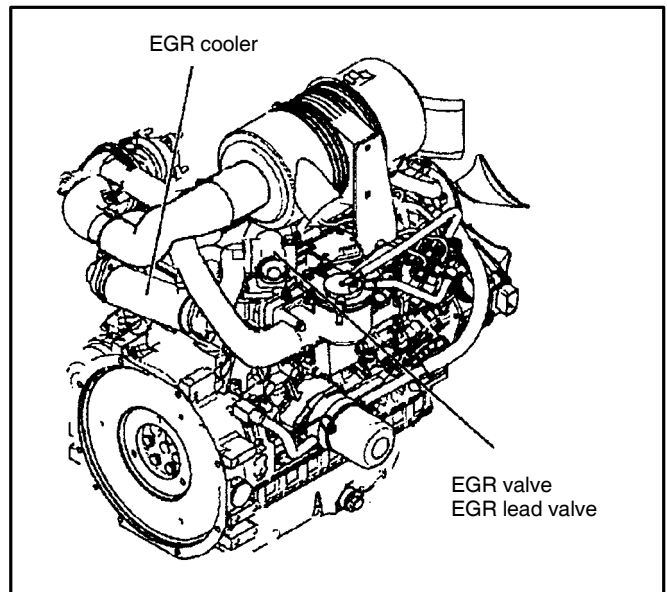
**(6) Inspect Crankcase Breather System**

Proper operation of the crankcase breather system is required to maintain the emission requirements of the engine. The EPA/ARB requires that you have the crankcase breather system inspected every 1500 hours. See your authorized Portable Power dealer or distributor for this service.

Inspection every 2000 hours operation

(1) Flushing the cooling system and checking the cooling system parts

As this maintenance requires specialized knowledge and skill, consult your Portable Power dealer. Rust and water scale will accumulate in the cooling system through many hours of operation. This lowers the engine cooling effect.

(2) Checking and replacing fuel hoses and cooling water hoses

As this maintenance requires specialized knowledge and skill, consult your Portable Power dealer. Regularly check the rubber hoses of the fuel system and cooling water system. If cracked or degraded, replace them with new one. Replace the rubber hoses at least every 2 years.

(3) Lapping the intake and exhaust valves

As this maintenance requires specialized knowledge and skill, consult your Portable Power dealer. The adjustment is necessary to maintain proper contact of the valves and seats.

(4) Checking and adjusting the fuel injection timing

As this maintenance requires specialized knowledge and skill, consult your Portable Power dealer.

(5) Checking and adjusting the EPA emission related parts.

The inspection and servicing require specialized knowledge and techniques. Consult your Portable Power dealer or distributor.

EPA allows to apply maintenance schedule for emission related parts as follow.

Diagnosis Tool

A connector is provided at an end of the harness of the driven machine so that the diagnosis tool can be loaded with data from the E-ECU.

When the fuel injection pump is replaced, data in the E-ECU must also be replaced for accomodating the new pump. When the EECU is replaced, the fuel injection data in the existing unit must be migrated to the new unit. The diagnosis tool can be used for the data replacement or migration. Contact your local Portable Power dealer for replacement of the fuel injection pump or E-ECU.

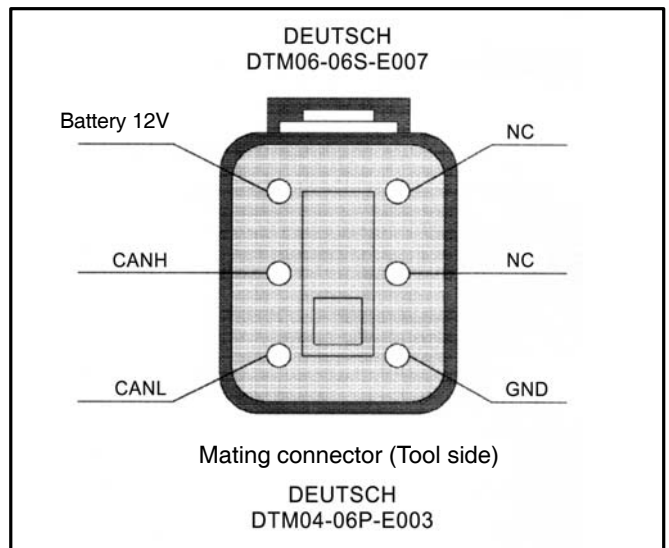
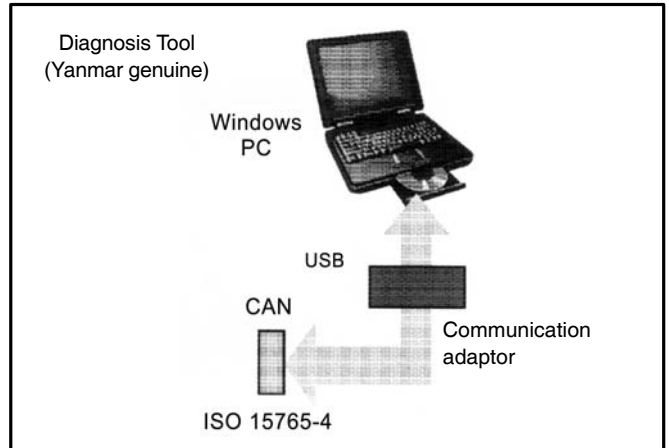

This item contains a simple troubleshooting. When a failure takes place on your Portable Power engine, diagnose the cause referring this troubleshooting. Should the cause of failure not be detected or you are unable to manage the failure, consult your machine supply source or nearest Portable Power engine service outlet.

Engine does not start	Starter does not turn.	Battery discharged	
		Bad cable connections.	
		Starter or starter switch failure.	
		Safety relay failure.	
	Starter turns but engine does not fire.	No fuel injection.	No fuel in the fuel tank.
			Clogged fuel filter element.
			Air in the fuel system.
			Control rack is stuck at no fuel position.
		Fuel is injected but engine does not fire.	Incorrect preheating operation.
			Faulty air heater.
	Incorrect injection timing.		
	Low cylinder compression pressure.		
Engine fires but stalls immediately.	Air in the fuel system.		

A connector is provided at an end of the harness of the driven machine so that the diagnosis tool can be loaded with data from the E-ECU.

Unstable engine running	Unstable low idling	Crack in injection pipe.	
		Injection nozzle failure.	
		Uneven compression pressure between cylinders.	
	Incorrect high idle speed adjustment.	Software/Electronic malfunction.	
	Engine hunting in medium speed range.	Software/Electronic malfunction.	
	Engine malfunction in high speed range.	Insufficient fuel supply.	Air in the fuel system
			Clogged fuel filter element
			Piping failure (squeezed/restricted etc.)
		Uneven fuel injection amount between cylinders.	
		Incorrect valve clearance adjustment.	
Deteriorated valve spring.			
Engine speed stuck at high idle.	Engine control restriction or seizure.		
Engine overheat.	Cooling system defect	Insufficient coolant volume.	
		Fan belt slippage.	
		Thermostat malfunction.	
		Radiator filler cap malfunction.	
		Cooling system interior fouled.	
		Radiator clogged.	
	Improper servicing	Engine over-loaded.	
		Air cleaner element clogged.	
		Insufficient airflow/restriction.	
		Restricted coolant flow (high concentration of antifreeze, etc.)	
Low oil pressure	Lack of oil	Oil leakage	
		High oil consumption	
	Wrong oil	Wrong type and viscosity.	
	High coolant temperature.	Over heat.	
	Clogged filter and strainer.	Clean and/or replace.	
	Worn bearings and oil pump.	Replace.	
	Faulty relief valve.	Replace.	

Low engine output	Incorrect injection pump adjustment	Incorrect injection timing	Too far advanced.
			Too far retarded.
		Injection nozzle malfunction	Incorrect injection pressure.
			Incorrect spray condition.
		Insufficient fuel supply to the injection pump	Lack of fuel in tank.
		Air in injection pump.	
		Fuel filter clogged.	
		Overflow valve malfunction.	
		Governor malfunction	Incorrect engine control adjustment.
			Deteriorated governor spring.
Low cylinder compression pressure	Cylinder compression leakage		Incorrect valve clearance adjustment.
			Injector nozzle misalignment.
			Cylinder bore wear.
	Insufficient air intake volume.	Air cleaner clogged.	
		Restricted air flow.	
Excessive oil consumption	Incorrect oil	Wrong selection of type and viscosity.	
		Too much oil quantity.	
	Engine burning oil	Faulty piston rings/damaged cylinder bores.	
		Faulty valve stem seal.	
	Oil leakage	Damaged seal / Damaged turbocharger seal	
		Loose joints/gaskets.	
Improper installation of filter and piping.			
Excessive fuel consumption	Fuel leakage	Damaged seals.	
		Improper component installation or tightening.	
	Excessive injection volume.	Injection pump defective.	
	Excessive mechanical loads		

Improper exhaust	Excessive black smoke	Clogged air cleaner.
		Damaged injector nozzle.
		Faulty EGR Valve
		Injection timing incorrect.
		Excessive injection volume.
		Incorrect fuel.
	Excessive white smoke	Water mixing in fuel
		Low compression pressure.
		Injection timing incorrect.
		Low coolant temperature
	Faulty turbocharger	
Battery over discharge	Low electrolyte level	Crack in battery body.
		Natural consumption.
	Charging failure	Loose or damaged belt.
		Faulty alternator.
		Damaged wiring or contact failure.
	Excessive electrical loads	Insufficient battery capacity for the application.

